



Assembly manual



General designation

ELDRO® "New Generation" electro-hydraulic lifting thruster

Type designation

ED 120 to ED 3500 (three-phase current version)

Status:

03.2024

Table of contents

1	General.....	6
1.1	Information about this assembly manual	6
1.2	Manufacturer.....	6
1.3	Validity.....	7
1.4	Further applicable documents.....	7
1.5	Formal information about this assembly manual	7
1.6	Format conventions	8
1.7	Structure of warning notices	9
1.8	Terms and abbreviations.....	10
2	Safety	11
2.1	Intended use	11
2.2	Unintended use	12
2.3	Staff qualifications	12
2.3.1	Qualified personnel	13
2.3.2	Qualified electrician	13
2.3.3	Maintenance personnel.....	14
2.3.4	Responsible staff.....	15
2.4	Personal protective equipment.....	15
2.5	Electrical operating equipment.....	16
2.6	Process media	17
2.7	Modifications	17
2.8	Spare and wear parts.....	17
3	Technical data	18
3.1	Type designation and type key.....	18
3.2	Specifications on the type plate	19
3.3	Characteristics	20
3.4	Dimensions	26
3.4.1	Type ED120 / ED220	26
3.4.2	Type ED300 / ED500	27
3.4.3	Type ED500 / ED800 / ED1250	28
3.4.4	Type ED1250 – ED3500	30
3.5	Airborne sound emissions.....	32
3.6	Operating conditions	32
3.6.1	Ambient temperature.....	32
3.6.2	Air humidity.....	33
3.6.3	Aggressive ambient conditions	33
3.6.4	Voltage and frequency tolerances.....	33

3.6.5	Installation height	33
4	Functional description.....	34
4.1	Mechanical layout	35
4.1.1	ED120 / ED220	35
4.1.2	ED300 / ED500	36
4.1.3	ED500 / ED1250	37
4.1.4	ED1250 / ED3500	37
4.1.5	Rotatable thruster base	38
4.1.6	Cable gland	39
4.2	Electrical equipment	40
4.2.1	Internal lift path monitoring	40
4.2.2	Low temperature heating	41
4.3	Functional description.....	42
5	Transport and storage	43
5.1	Transport.....	43
5.1.1	Transport sketch	44
5.2	Storage	45
6	Assembly and installation.....	46
6.1	Assembly	46
6.1.1	Permissible installation positions	48
6.1.2	Installing the ELDRO® thruster.....	49
6.2	Electrical connection	50
6.2.1	Junction box and terminal diagram	51
6.2.2	Earthing conductor connection.....	55
6.2.3	Power supply connection	55
6.2.4	ELDRO® thrusters with additional heating	56
6.3	Adjusting the valves	58
6.3.1	Adjustment screw installation location	58
6.3.2	Changing the set time and the reset time	59
6.4	Rotating the thruster base	60
6.5	Completing assembly	60
7	Notes on operation	61
7.1	Checking the operating conditions prior to starting up	63
8	Help with malfunctions.....	64
8.1	Faults and troubleshooting.....	64
9	Maintenance	66
9.1	Maintenance tasks	66
9.1.1	Operating fluid.....	68

9.1.2	Checking the operating fluid.....	69
9.1.3	Seals	71
9.2	Maintenance schedule.....	72
9.2.1	Classification	73
10	Disassembly	74
10.1	Disconnecting the electrical connections	75
10.2	Removal	75
11	Disposal.....	77
11.1	Disposal consideration.....	77
12	Lists	78
12.1	Index of figures.....	78
12.2	Index of tables	78
13	Appendix.....	80
13.1	Further applicable documents.....	80

1 General

1.1 Information about this assembly manual



1 General

1.1 Information about this assembly manual

This assembly manual was prepared according to the principles of the technical editing and the minimum legal requirements of directive 2006/42/EU used as a basis. The assembly manual enables the safe and efficient operation of the ELDRO® "New Generation" electro-hydraulic lifting thruster (subsequently referred to as ELDRO® thruster).

This assembly manual is part of the ELDRO® thruster and must be kept in its immediate vicinity and accessible to staff at all times.

The staff must have read this assembly manual carefully and understood it before starting any work.

Version	Description	Date	Author
V1-0	First draft	22/02/2022	CE Design
V1-1	Characteristics updated	13/11/2023	Holterhoff
V1-2	Update terminal diagram	30/01/2024	Musalf
V1-3	Update Reed-contacts	11/03/2024	Musalf

1.2 Manufacturer

EMG Automation GmbH
Industriestr. 1
D-57482 Wenden / Germany

Telephone +49 2762 612 0
Fax +49 2762 612 320

E-mail info@emg-automation.com
Internet www.emg-automation.com

1.3 Validity

This manual corresponds to the technical state of the ELDRO® thruster at the time of issue. The contents of this manual are not contractually binding but are provided as information.

EMG Automation GmbH reserves the right to make content and technical changes compared to this manual without having to specify these. EMG Automation GmbH cannot be held responsible for any inaccuracies or incorrect specifications in this manual, which are caused by content and technical changes after delivering this ELDRO® thruster, as there is no obligation to update this manual continually.

1.4 Further applicable documents

All documents listed in the appendix (further applicable documents) to this assembly manual must be observed.

1.5 Formal information about this assembly manual





© Copyright, 2021

All rights reserved.

Reprinting, including excerpts, is only permissible with the approval of EMG Automation GmbH.

1.6 Format conventions

Table 1. Format conventions

Format	Meaning
1. Action	Action step with a sequence
▪	Action step / user instruction
–	List
"ABC"	Highlighting of special terms in the text
⇒	Reference to chapters or sections of this assembly manual or to further applicable documents (e.g ⇒Technical data chapter)
	This signal word indicates an immediate threat of danger. If this danger is not avoided, this will result in death or serious injuries.
	This signal word indicates a possible danger. If this danger is not avoided, this may result in death or serious injuries.
	This signal word indicates a possibly dangerous situation. If this dangerous situation is not avoided, this may result in minor or moderate injuries.
	This signal word indicates actions for preventing property damage. Observing this information prevents damage or destruction of the ELDRO® thruster.
	Supplementary information

1.7 Structure of warning notices

If observed, warning notices protect against possible personal injury and property damage and classify the extent of the danger by the signal word.

 WARNING = Signal word
Source of danger Possible consequences of non-compliance – Measures for avoidance/prohibited actions

Hazard signs

The hazard sign indicates warning information that alerts you of personal injury hazards.

Source of danger

The source of the danger indicates the cause of the hazard.

Possible consequences of non-compliance

The possible consequences when failing to observe the warning information are bruises, burns or other serious injuries.

Measures/prohibited actions

Measures / prohibited actions contains a list of instructions that must be implemented in order to avoid a hazard or that are prohibited in order to avoid a hazard.

1.8 Terms and abbreviations

The following terms and abbreviations are used in the assembly manual.

Table 2. Terms and abbreviations

Term/abbreviation	Meaning
Brake spring	Cylindrical pressure spring that counteracts the hydraulic force. As a result, only the force difference on the lifting rod is effective as the actuating force.
Damping spring (d spring)	Spring for gentle braking. This reduces the braking force by applying the brake shoes continuously until the stop value is reached. When bleeding the brake, the braking force reduces continuously from the highest value to zero (releasing the brake shoes).
ELDRO® thruster	Electro-hydraulic lifting thruster that converts electrical energy into mechanical energy in a straight line movement by hydraulic means.
Highest value for additional load	Total of the forces that apply to the lifting rod head and that affect the lifting movement and setting time, e.g. friction and mass of the connection elements.
Lifting valve H	Valve to reduce the lifting speed
Lifting and lowering valve HS	Valves to reduce the lifting and lowering speeds
Lifting time	Time from switching the motor on until the top piston limit position is reached.
Nominal operating point	Operating point that is at 1/3 of the nominal lift.
Nominal lift	Maximum path that the extending lifting rod can take.
Nominal reset force	Minimum force at the nominal operating point for a machine with reset spring c.
Nominal actuating force	Usable hydraulic force on the lifting rod head for a machine without reset spring c.
Regulation braking	Braking to regulate three-phase motors to low speeds, virtually independent of the load. A pump wheel with optimum adjustment determines the hydraulic force with the nominal reset force. Thrusters for regulation braking are equipped with reset spring c and damping spring d.
Regulation spring	See damping spring
Reset spring c	See brake spring
Lowering valve S	Valve to reduce the lowering speed
Lowering time	Time from switching the motor off until the bottom piston limit position is reached.

2 Safety

ELDRO® lifting thrusters are reliable electro-hydraulic machines for use in industrial systems. They are state of the art.

The generally applicable regulations and other binding directives regarding health and safety, accident prevention and environmental protection must be adhered to.

The following safety regulations must be adhered to before beginning any work on ELDRO® thrusters:

- Ensure that the industrial system is shut down
- De-energise the system
- Safeguard the system to prevent it being switched on again
- Test to ensure a de-energised state
- Cover or isolate adjacent live parts

2.1 Intended use

The ELDRO® thruster is partly completed machinery and must be connected to other parts to form a complete machine. The safety of this complete machine must prevent hazards caused by controlling and operating the system.

ELDRO® thrusters are used to apply straight work movements using electro-hydraulics. In drive technology, drives are braked or stopped using brakes with electro-hydraulic actuation thrusters (lifting thrusters). ELDRO® thrusters are mainly used in drive technology to bleed drum and disc brakes (brake bleeder).

However, ELDRO® thrusters can also be used in other areas of production, transport technology, warehousing and handling technology, wherever a straight work movement is required and a single drive is wanted. Applications as an actuator include actuating

- valves
- couplings
- slides
- throttle valves
- locking thrusters

Intended use also includes adhering to the assembly, operating and maintenance procedures described in this assembly manual.

The technical data and the specifications for terminal assignments are specified on the type plate and in the manual, and must be adhered to.

ELDRO® thrusters may only be operated in the permissible installation position and operating mode. Only this intended use is permissible. Any other use is prohibited.

2.2 Unintended use

Reasonably foreseeable misuse

Any unintended use or impermissible operating modes constitutes misuse of the ELDRO® thrusters. For safety reasons, all applications not listed in the intended use section are strictly prohibited by the manufacturer.

All applications as an actuator always require confirmation from the manufacturer. Applications as actuators that cause the power supply for retracting the lifting rod to fail are not permitted due to the associated risk of accidents.

2.3 Staff qualifications

Qualified staff must be used for the ELDRO® thruster's intended use. The scope of responsibility, authority and supervision of personnel must be precisely stipulated by the operating company.

Qualified staff are people who, due to their training, experience and instruction, as well as their knowledge of applicable standards, regulations, accident prevention regulations and operating conditions, are authorised by the person responsible for system safety to perform the relevant required tasks and are thereby able to identify and avoid possible hazards.

Work on or with ELDRO® thrusters may only be performed by trained and qualified staff who have received system-specific instructions, who are authorised to do so and who have special knowledge and experience with the corresponding field.

Contact EMG Automation GmbH if the required staff qualifications are unclear.

2.3.1 Qualified personnel

ELDRO® thrusters may only be transported, set up, connected, operated and maintained by specialists. All work must be performed with the intended, intact tools, equipment, test equipment and consumables, and must be inspected by the specialists responsible. The specialists must be authorised to perform the required tasks by the person responsible for the industrial system's safety.

Specialists include industrial mechanics or people who have comparable, country-specific training and who have the following knowledge:

- Knowledge and experience in transporting, storing, assembling and disposing of the ELDRO® thrusters
- Knowledge and experience of the electrical, mechanical and hydraulic equipment on the components for the ELDRO® thrusters
- ELDRO® thruster functions
- Modifying the ELDRO® thrusters and re-adjusting them properly
- Hazards on the system and suitable safety measures

2.3.2 Qualified electrician

Electrical specialists include electricians, who

- due to their technical training, knowledge, and experience, as well as knowledge of applicable standards and regulations, are capable of carrying out work on electrical systems
- have been commissioned and trained by the operating company to perform work on electrical systems and equipment on the ELDRO® thrusters
- are familiar with the ELDRO® thruster functions
- can detect and avoid possible hazards by taking suitable safety measures.

2.3.3 Maintenance personnel

Maintenance staff include industrial mechanics or people who have comparable, country-specific training. Maintenance staff are people who have been commissioned by the operating company to maintain the system and who have the following knowledge:

- Knowledge and experience of the electrical, mechanical and hydraulic equipment on the components for the ELDRO® thrusters
- ELDRO® thruster functions and maintenance points
- Hazards on the system and suitable safety measures
- Lubricating, cleaning, preserving, topping up to replacing consumables
- Replacing wear parts
- Modifying the ELDRO® thrusters and re-adjusting them properly

2.3.4 Responsible staff

The following table provides you with information on the staff qualifications that are the prerequisites for the corresponding tasks. Only people who have the corresponding qualification may perform these tasks.

Table 3. Responsible staff

Task	Responsible staff			Manufacturer or service partner authorised by the manufacturer
	Qualified personnel	Qualified electrician	Maintenance personnel	
Transport	x			
Assembly	x			
Electrical installation		x		
Starting up	x			
Shutting down	x			
Fault rectification	x		x	x
Electrical fault rectification		x		x
Maintenance	x		x	
Repairs	x			x
Electrical repairs		x		x
Dismantling	x			
Storage	x			
Disposal	x			x

Contact EMG Automation GmbH if the required staff responsibilities are unclear.

2.4 Personal protective equipment

The operating company must prescribe personal protective equipment according to the danger risk. Personal protective equipment includes the following among others:

- safety shoes, work clothing, protective clothing if required
- protective gloves
- hard hat
- safety goggles

This list of personal protective equipment is not exhaustive.

2.5 Electrical operating equipment

- Work on electrical equipment must be carried out exclusively by electricians.
- When performing any work on electrical components, the five safety rules must be adhered to:
 - Disconnect from the electrical supply
 - Safeguard to prevent a restart
 - Test to ensure a de-energised state
 - Earth and short-circuit
 - Cover or isolate adjacent live parts
- Perform regular checks for insulation and housing damage.
- The ELDRO® thruster must never be operated with electrical connections that are faulty or not ready for operation.
- If there are power supply faults, the system must be switched off immediately.
- Before any work on electrical components, switch the mains disconnection thruster off and secure it to prevent it being switched on again.
- It is essential to observe the inspection and maintenance intervals specified by the manufacturer for electrical components.
- All touchable, conductive parts of the system are connected to the external earthing conductor system. The earthing conductor system must be inspected after performing maintenance work (e.g. replacing components).
- Some equipment (e.g. mains power units, servo controllers, converters) with electrical intermediate circuits may store residual voltage for a certain time after being disconnected. Before starting work on these systems, check that they are de-energised.

2.6 Process media

- The instructions on the manufacturer's material safety data sheets must be followed.
- Contact with eyes or the skin should be avoided.
- Avoid inhaling vapours or mist.
- Soak up any spilled or leaking process media immediately with a binding agent and dispose of it properly.
- Keep containers with flammable substances and compressed, liquefied gases away from sources of heat.

2.7 Modifications

Changes, attachments and modifications to ELDRO® components, which could impair safety or functions may not be performed without written approval from the manufacturer.

2.8 Spare and wear parts

The use of spare and wear parts from third-party manufacturers may lead to risks. Only original parts or spare and wearing parts approved by the manufacturer may be used.



For information regarding replacement thrusters for ELDRO® types that can no longer be supplied, see the "Ordering notes for replacement thrusters" list.

3 Technical data

3.1 Type designation and type key



3 Technical data

3.1 Type designation and type key

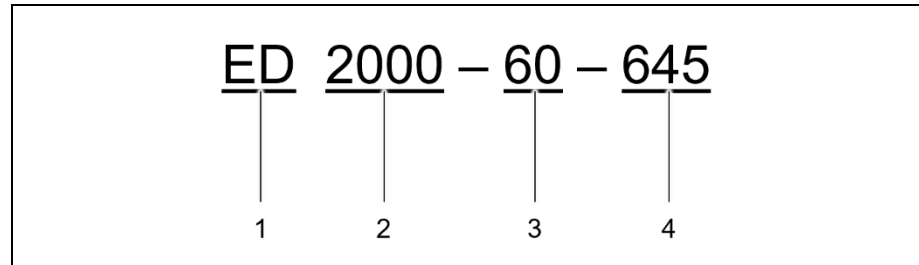

Figure 1. Type designation and type key

- 1 ED: ELDRO®, three-phase version
- 2 Lifting force in N
- 3 Lifting path in mm
- 4 Installation dimension in mm

3.2 Specifications on the type plate

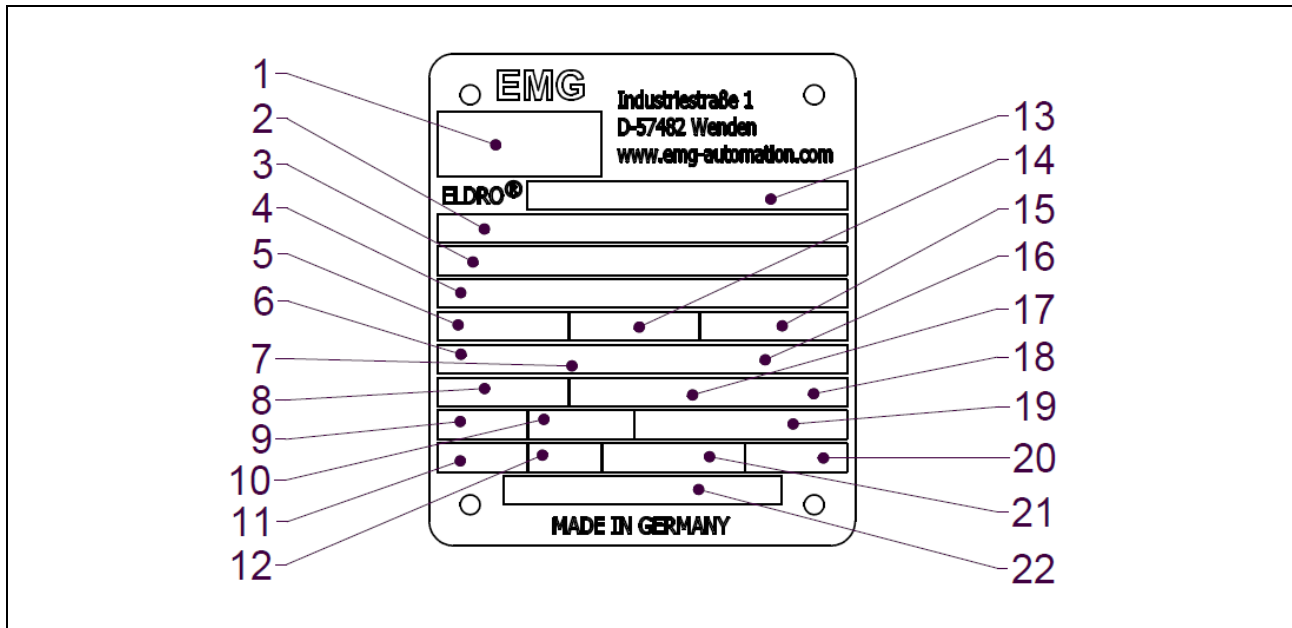

Figure 2. Type plate

1	Standard	12	Protection category
2	Equipment	13	Thruster type
3	Serial number	14	Lifting path in mm
4	Return force	15	Year of construction
5	Lifting force in N	16	Switching processes per hour
6	Operating mode	17	Voltage
7	Switch-on duration in %	18	Voltage tolerance
8	Switching type	19	Current consumption
9	Frequency	20	Weight
10	Power consumption	21	Operating fluid
11	Insulation class	22	Temperature range

3.3 Characteristics



All characteristic data is mean values related to +20 °C working temperature of the thruster.

Missing information was not yet available at the time of going to press. If necessary, contact the manufacturer.

ED120 / ED220

Table 4. ED120 / ED220 key data

ELDRO® type	ED120-40-286	ED120-40-400	ED120-50-286	ED220-50-286	ED220-50-314
Lifting force [N]	120	120	120	220	220
Lifting path [mm]	40	40	50	50	50
Installation dimension [mm]	286	400	286	286	314
Brake spring force (c spring) ¹⁾ [N]	Consultation with manufacturer required				
Power consumption [W]	140	140	140	140	140
Current consumption at 400 V ²⁾ [A]	0,25			0,25	0,25
Switching frequency at S3-60% ED ³⁾ [c/h]	2000	2000	2000	2000	2000
Weight [kg]	11		11	11	

- 1) Brake force values apply at 1/3 of the nominal lifting path
- 2) Values for the piston's mechanical limit positions. The specified values increase during the lifting process. At a thruster working temperature of -25 °C, the current consumption is around 1.5 that of the current consumption at +20 °C.
- 3) Continuous operation S1 and intermittent operation S3 are permitted up to an ambient temperature of +50 °C

ED300

Table 5. ED300 key data

ELDRO® type	ED300-50-370	ED300-50-385	ED300-50-445	ED300-60-370	ED300-100-493
Lifting force [N]	300	300	300	300	300
Lifting path [mm]	50	50	50	50	100
Installation dimension [mm]	370	385	445	370	493
Brake spring force (c spring) ¹⁾ [N]	Consultation with manufacturer required				
Power consumption [W]	200	200	200	200	200
Current consumption at 400 V ²⁾ [A]	0,3	0,3		0,3	
Switching frequency at S3-60% ED ³⁾ [c/h]	2000	2000	2000	2000	2000
Weight [kg]	15	15		15	

- 1) Brake force values apply at 1/3 of the nominal lifting path
- 2) Values for the piston's mechanical limit positions. The specified values increase during the lifting process. At a thruster working temperature of -25 °C, the current consumption is around 1.5 that of the current consumption at +20 °C.
- 3) Continuous operation S1 and intermittent operation S3 are permitted up to an ambient temperature of +50 °C

ED500

Table 6. ED500 key data

ELDRO® type	ED500-50-370	ED500-50-400	ED500-60-370	ED500-60-400	ED500-60-435	ED500-70-435	ED500-100-452	ED500-100-515	ED500-120-515
Lifting force [N]	500	500	500	500	500	500	500	500	500
Lifting path [mm]	50	50	60	60	60	70	100	100	100
Installation dimension [mm]	370	400	370	400	435	435	452	515	515
Brake spring force (c spring) ¹⁾ [N]	Consultation with manufacturer required								
Power consumption [W]	200	200	200	200	200	200	200	200	200
Current consumption at 400 V ²⁾ [A]	0,35	0,35	0,35	0,35					
Switching frequency at S3-60% ED ³⁾ [c/h]	2000	2000	2000	2000	2000	2000	2000	2000	2000
Weight [kg]	15	15	15	15					

- 1) Brake force values apply at 1/3 of the nominal lifting path
- 2) Values for the piston's mechanical limit positions. The specified values increase during the lifting process. At a thruster working temperature of -25 °C, the current consumption is around 1.5 that of the current consumption at +20 °C.
- 3) Continuous operation S1 and intermittent operation S3 are permitted up to an ambient temperature of +50 °C

3 Technical data

3.3 Characteristics



ED800

Table 7. ED800 key data

ELDRO® type	ED800-25-458	ED800-50-458	ED800-60-458	ED800-70-450	ED800-75-458	ED800-120-530
Lifting force [N]	800	800	800	800	800	800
Lifting path [mm]	25	50	60	70	75	120
Installation dimension [mm]	458	458	458	450	458	530
Brake spring force (c spring) ¹⁾ [N]	Consultation with manufacturer required					
Power consumption [W]	330	330	330	330	330	330
Current consumption at 400 V ²⁾ [A]						
Switching frequency at S3-60% ED ³⁾ [c/h]						
Weight [kg]						

- 1) Brake force values apply at 1/3 of the nominal lifting path
- 2) Values for the piston's mechanical limit positions. The specified values increase during the lifting process. At a thruster working temperature of -25 °C, the current consumption is around 1.5 that of the current consumption at +20 °C.
- 3) Continuous operation S1 and intermittent operation S3 are permitted up to an ambient temperature of +50 °C

ED1250

Table 8. ED1250 key data

ELDRO® type	ED1250-25-458	ED1250-60-458	ED1250-60-645	ED1250-70-450	ED1250-75-458	ED1250-120-705	ED1250-160-573	ED1250-160-705
Lifting force [N]	1250	1250	1250	1250	1250	1250	1250	1250
Lifting path [mm]	25	60	60	70	75	120	160	160
Installation dimension [mm]	458	645	458	450	458	705	573	705
Brake spring force (c spring) ¹⁾ [N]	Consultation with manufacturer required							
Power consumption [W]	330	330	330	330	330	330	330	330
Current consumption at 400 V ²⁾ [A]								
Switching frequency at S3-60% ED ³⁾ [c/h]								
Weight [kg]								

- 1) Brake force values apply at 1/3 of the nominal lifting path
- 2) Values for the piston's mechanical limit positions. The specified values increase during the lifting process. At a thruster working temperature of -25 °C, the current consumption is around 1.5 that of the current consumption at +20 °C.
- 3) Continuous operation S1 and intermittent operation S3 are permitted up to an ambient temperature of +50 °C

ED1500

Table 9. ED1500 key data

ELDRO® type	ED1500-60-458	ED1500-60-645	ED1500-80-705	ED1500-120-573	ED1500-160-573	ED1500-160-705
Lifting force [N]	1500	1500	1500	1500	1500	1500
Lifting path [mm]	60	60	80	120	160	160
Installation dimension [mm]	458	645	705	573	573	705
Brake spring force (c spring) ¹⁾ [N]	Consultation with manufacturer required					
Power consumption [W]						
Current consumption at 400 V ²⁾ [A]						
Switching frequency at S3-60% ED ³⁾ [c/h]						
Weight [kg]						

- 1) Brake force values apply at 1/3 of the nominal lifting path
- 2) Values for the piston's mechanical limit positions. The specified values increase during the lifting process. At a thruster working temperature of -25 °C, the current consumption is around 1.5 that of the current consumption at +20 °C.
- 3) Continuous operation S1 and intermittent operation S3 are permitted up to an ambient temperature of +50 °C

ED1850 / ED2000

Table 10. ED1850 / ED2000 key data

ELDRO® type	ED1850-60-600	ED1850-160-700	ED2000-60-645	ED2000-70-705	ED2000-120-705
Lifting force [N]	1850	1850	2000	2000	2000
Lifting path [mm]	60	160	60	70	120
Installation dimension [mm]	600	700	645	705	705
Brake spring force (c spring) ¹⁾ [N]	Consultation with manufacturer required				
Power consumption [W]					
Current consumption at 400 V ²⁾ [A]					
Switching frequency at S3-60% ED ³⁾ [c/h]					
Weight [kg]					

- 1) Brake force values apply at 1/3 of the nominal lifting path
- 2) Values for the piston's mechanical limit positions. The specified values increase during the lifting process. At a thruster working temperature of -25 °C, the current consumption is around 1.5 that of the current consumption at +20 °C.
- 3) Continuous operation S1 and intermittent operation S3 are permitted up to an ambient temperature of +50 °C

3 Technical data

3.3 Characteristics



ED2500

Table 11. ED2500 key data

ELDRO® type	ED2500-40-549	ED2500-60-549	ED2500-60-645	ED2500-70-705	ED2500-80-645	ED2500-80-705	ED2500-125-660	ED2500-150-660	ED2500-160-660	ED2500-160-705	ED2500-175-660
Lifting force [N]	2500	2500	2500	2500	2500	2500	2500	2500	2500	2500	2500
Lifting path [mm]	40	60	60	70	80	80	125	150	160	160	175
Installation dimension [mm]	549	549	645	705	645	705	660	660	660	705	660
Brake spring force (c spring) ¹⁾ [N]	Consultation with manufacturer required										
Power consumption [W]											
Current consumption at 400 V ²⁾ [A]											
Switching frequency at S3-60% ED ³⁾ [c/h]											
Weight [kg]											

- 1) Brake force values apply at 1/3 of the nominal lifting path
- 2) Values for the piston's mechanical limit positions. The specified values increase during the lifting process. At a thruster working temperature of -25 °C, the current consumption is around 1.5 that of the current consumption at +20 °C.
- 3) Continuous operation S1 and intermittent operation S3 are permitted up to an ambient temperature of +50 °C

ED3000

Table 12. ED3000 key data

ELDRO® type	ED3000-60-645	ED3000-60-660	ED3000-70-705	ED3000-80-645	ED3000-80-660	ED3000-120-705
Lifting force [N]	3000	3000	3000	3000	3000	3000
Lifting path [mm]	60	60	70	80	80	120
Installation dimension [mm]	645	660	705	645	660	705
Brake spring force (c spring) ¹⁾ [N]	Consultation with manufacturer required					
Power consumption [W]						
Current consumption at 400 V ²⁾ [A]						
Switching frequency at S3-60% ED ³⁾ [c/h]						
Weight [kg]						

- 1) Brake force values apply at 1/3 of the nominal lifting path
- 2) Values for the piston's mechanical limit positions. The specified values increase during the lifting process. At a thruster working temperature of -25 °C, the current consumption is around 1.5 that of the current consumption at +20 °C.
- 3) Continuous operation S1 and intermittent operation S3 are permitted up to an ambient temperature of +50 °C

ED3500

Table 13. ED3500 key data

ELDRO® type	ED3500-50-825	ED3500-60-645	ED3500-70-705	ED3500-80-705	ED3500-100-660	ED3500-120-660	ED3500-125-660
Lifting force [N]	3500	3500	3500	3500	3500	3500	3500
Lifting path [mm]	50	60	70	80	100	120	125
Installation dimension [mm]	825	645	705	705	660	660	660
Brake spring force (c spring) ¹⁾ [N]	Consultation with manufacturer required						
Power consumption [W]							
Current consumption at 400 V ²⁾ [A]							
Switching frequency at S3-60% ED ³⁾ [c/h]							
Weight [kg]							

- 1) Brake force values apply at 1/3 of the nominal lifting path
- 2) Values for the piston's mechanical limit positions. The specified values increase during the lifting process. At a thruster working temperature of -25 °C, the current consumption is around 1.5 that of the current consumption at +20 °C.
- 3) Continuous operation S1 and intermittent operation S3 are permitted up to an ambient temperature of +50 °C

3 Technical data

3.4 Dimensions



3.4 Dimensions

3.4.1 Type ED120 / ED220

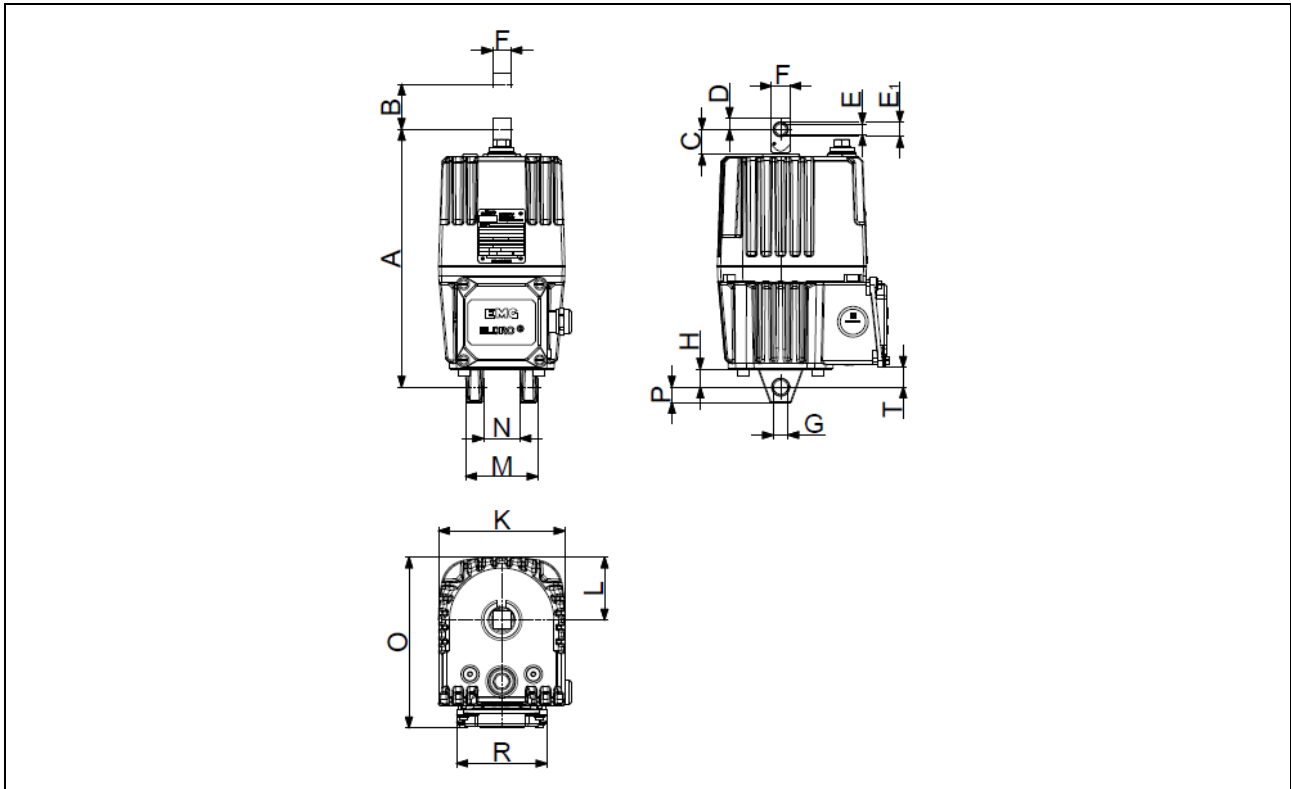

Figure 3. Type ED120 / ED220

Table 14. ED120 / ED220 dimensions

Type	A	B	C	D	E ¹⁾	E ¹⁾	F	G ²⁾	H	K	L	M	N	O	P	R	T
ED120-40-286	286	40	27	12	12	16	□ 20	16	20	140	70	80	40	190	17	100	22
ED120-50-286	286	50	27	12	12	16	□ 20	16	20	140	70	80	40	190	17	100	22
ED220-50-286	286	50	27	12	12	16	□ 20	16	20	140	70	80	40	190	17	100	22

1) Tolerance +0.1

2) Tolerance +0.15 to +0.25

(E can be converted to E1 by removing the clamping bush)

3.4.2 Type ED300 / ED500

Figure 4. Type ED300 / ED500

Table 15. ED300 / ED500 dimensions

Type	A	B	C	D	E ¹⁾	F	G ²⁾	H	K	L	M	N	O	P	R	T
ED300-50-370	370	50	34	15	16	□ 25	16	20	160	80	80	40	199	15	100	35.5
ED300-60-370	370	60	34	15	16	□ 25	16	20	160	80	80	40	199	15	100	35.5
ED500-50-370	370	50	34	15	16	□ 25	16	20	160	80	80	40	199	15	100	35.5
ED500-60-370	370	60	34	15	16	□ 25	16	20	160	80	80	40	199	15	100	35.5
ED500-50-400	400	50	53	17	12	∅ 21.5	20	31	160	80	80	40	199	20	100	46.5

1) Tolerance +0.1

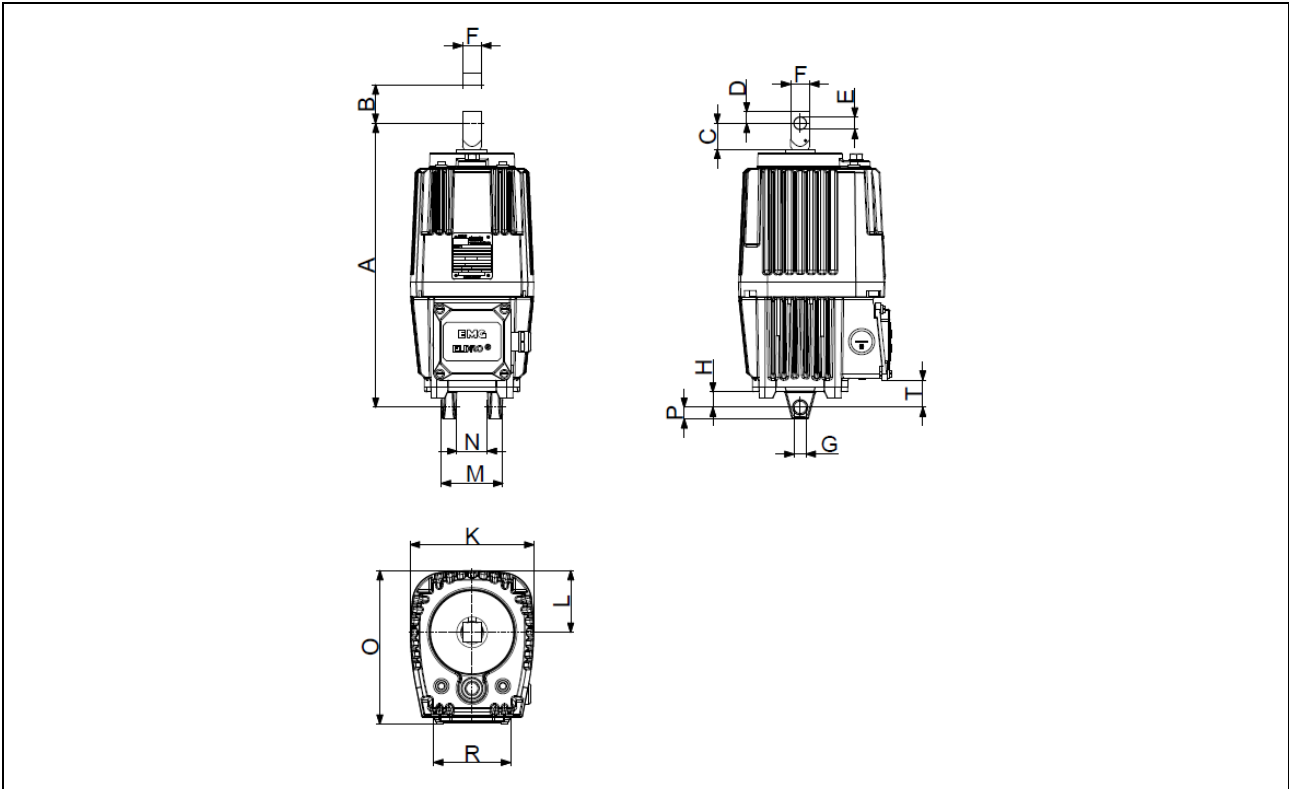
2) Tolerance +0.15 to +0.25

3.4.3 Type ED500 / ED800 / ED1250

Dimensions – Short lifting thrusters

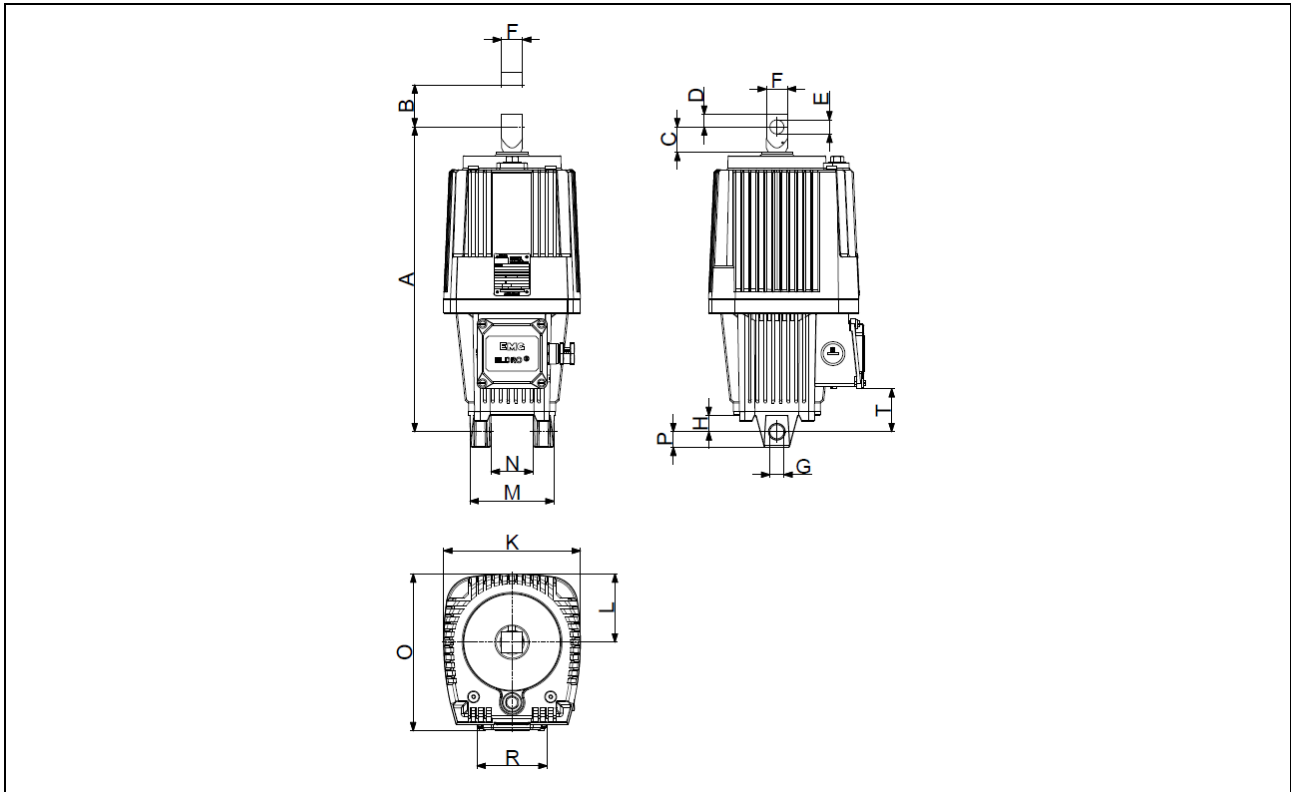

Figure 5. Type ED500 / ED800 / ED1250

Table 16. Dimensions ED500 / ED800 / ED1250 - Short lifting thrusters

Type	A	B	C	D	E ¹⁾	F	G ²⁾	H	K	L	M	N	O	P	R	T
ED500-60-435	435	60	36	18	20	□ 30	20	23	195	97.5	120	60	224	22	100	61.5
ED800-60-450	450	60	51	18	20	□ 30	20	23	195	97.5	120	60	224	22	100	61.5
ED1250-60-450	450	60	44	21	16	∅ 27.5	20.2	30	195	97.5	90	40	224	25	100	68.5
ED1250-70-450	450	70	51	18	20	□ 30	20	23	195	97.5	120	60	224	22	100	61.5

1) Tolerance +0.1

2) Tolerance +0.15 to +0.25

Dimensions – Long lifting thrusters

Figure 6. Type ED500 / ED800

Table 17. Dimensions ED500 / ED800 - Long lifting thrusters

Type	A	B	C	D	E ¹⁾	F	G ²⁾	H	K	L	M	N	O	P	R	T
ED500-120-515	515	120	56	18	20	□ 30	20	23	195	97.5	120	60	224	22	100	61.5
ED800-120-530	530	120	71	18	20	□ 30	20	23	195	97.5	120	60	224	22	100	61.5

1) Tolerance +0.1

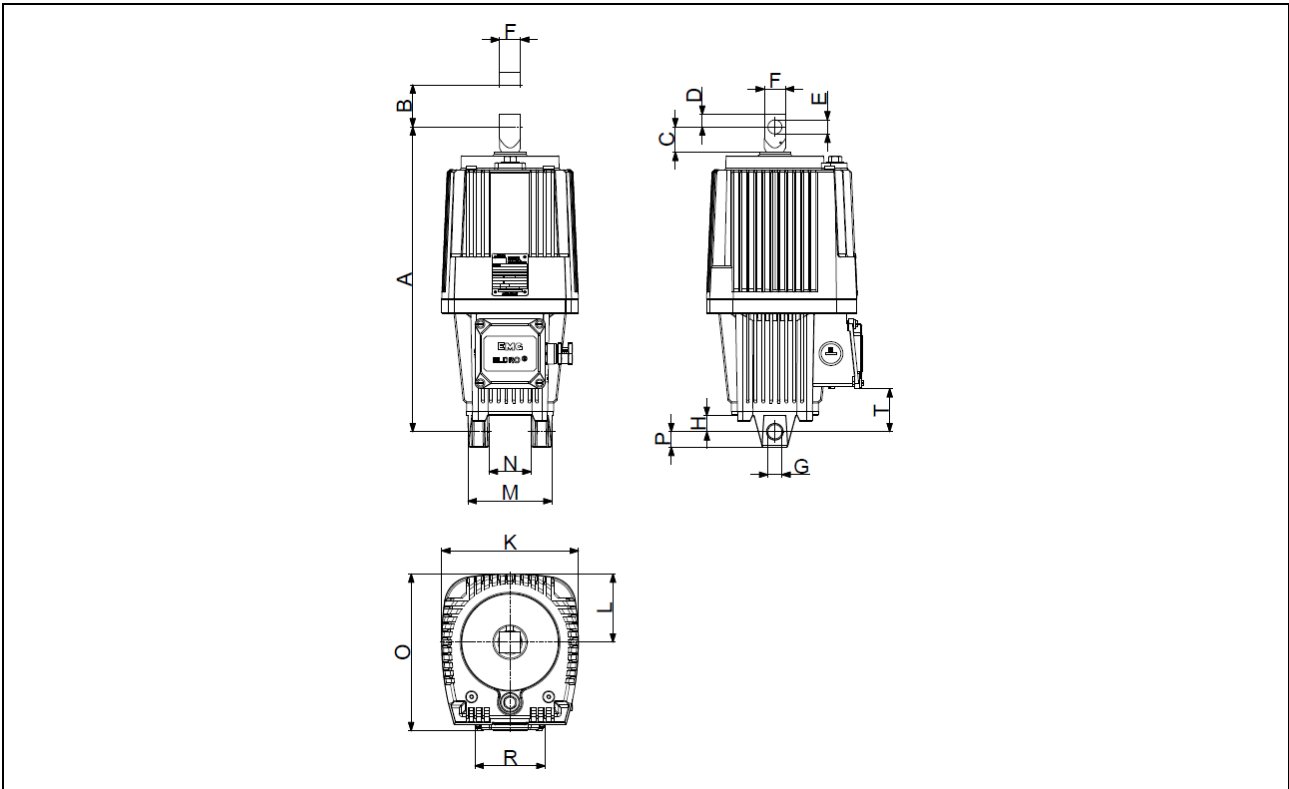
2) Tolerance +0.15 to +0.25

3.4.4 Type ED1250 – ED3500

Dimensions – Short lifting thrusters

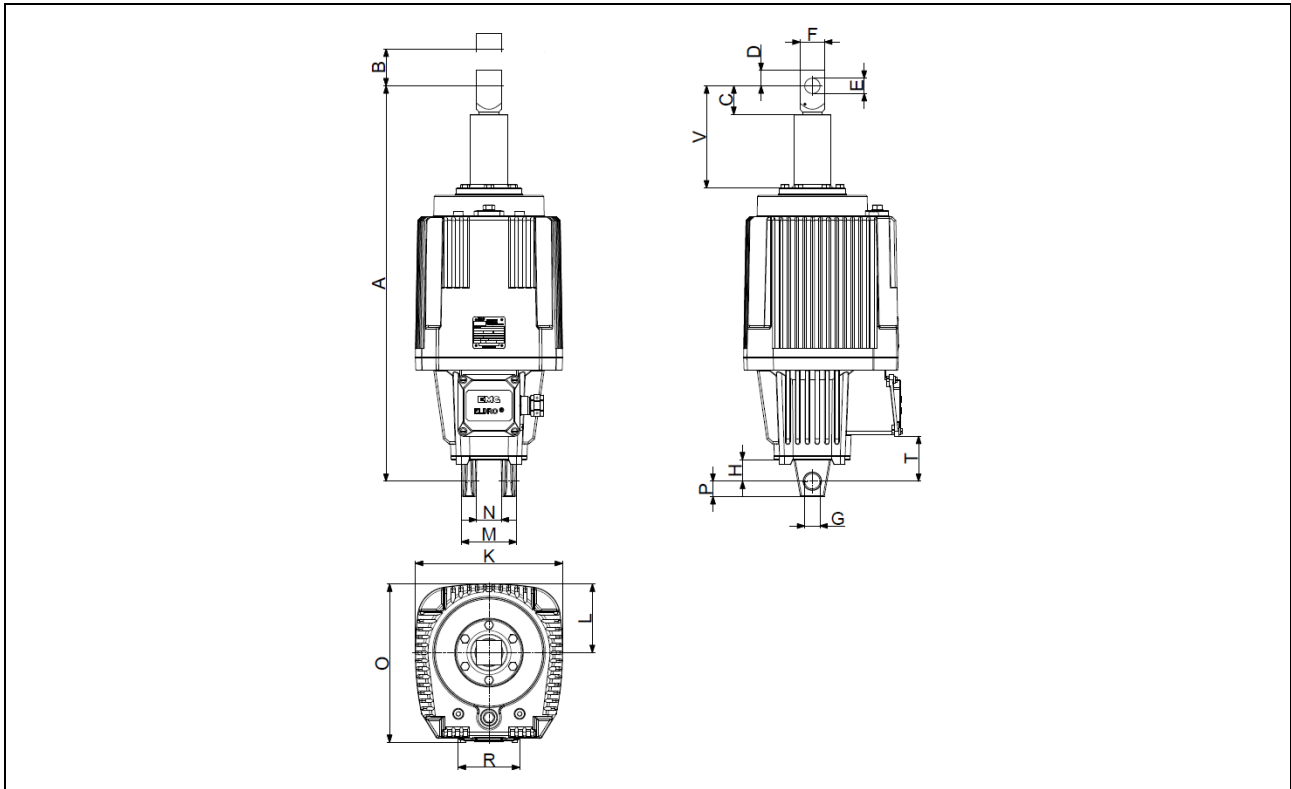

Figure 7. Type ED1250 – ED3500

Table 18. Dimensions ED1250 – ED3500 – Short lifting thrusters

Type	A	B	C	D	E ¹⁾	F	G ²⁾	H	K	L	M	N	O	P	R	T	V
ED1250-60-645	645	60	47	25	25	□ 40	25	35	240	112	90	40	260	25	100	73.5	167
ED1500-60-645	645	60	47	25	25	□ 40	25	35	240	112	90	40	260	25	100	73.5	167
ED1850-70-600	600	70	47	25	25	□ 40	25	35	240	112	90	40	260	25	100	73.5	122
ED2000-60-645	645	60	47	25	25	□ 40	25	35	240	112	90	40	260	25	100	73.5	167
ED2500-60-549	549	60	47	25	20	∅ 35.5	20.2	35	240	112	90	40	260	25	100	73.5	71
ED2500-60-645	645	60	47	25	25	□ 40	25	35	240	112	90	40	260	25	100	73.5	167
ED3000-60-645	645	60	47	25	25	□ 40	25	35	240	112	90	40	260	25	100	73.5	167
ED3000-60-660	660	60	62	25	25	□ 40	25	35	240	112	90	40	260	25	100	73.5	182
ED3000-80-645	645	60	47	25	25	□ 40	25	35	240	112	90	40	260	25	100	73.5	167
ED3500-80-660	660	60	62	25	25	□ 40	25	35	240	112	90	40	260	25	100	73.5	182

1) Tolerance +0.1

2) Tolerance +0.15 to +0.25

Dimensions – Long lifting thrusters

Figure 8. Type ED1250 – ED3500

Table 19. Dimensions ED1250 – ED3500 – Long lifting thrusters

Type	A	B	C	D	E ¹⁾	F	G ²⁾	H	K	L	M	N	O	P	R	T	V
ED1250-120-705	705	120	47	25	25	□ 40	25	35	240	112	90	40	260	25	100	73.5	147
ED1500-160-705	705	160	47	25	25	□ 40	25	35	240	112	90	40	260	25	100	73.5	147
ED1850-160-700	700	160	47	25	25	□ 40	25	35	240	112	90	40	260	25	100	73.5	142
ED2000-120-705	705	120	47	25	25	□ 40	25	35	240	112	90	40	260	25	100	73.5	147
ED2500-160-660	660	160	47	25	20	□ 40	25	35	240	112	90	40	260	25	100	73.5	102
ED2500-160-705	705	160	47	25	25	□ 40	25	35	240	112	90	40	260	25	100	73.5	147
ED3000-120-705	705	120	47	25	25	□ 40	25	35	240	112	90	40	260	25	100	73.5	147
ED3500-120-660	660	120	62	25	25	□ 40	25	35	240	112	90	40	260	25	100	73.5	102

1) Tolerance +0.1

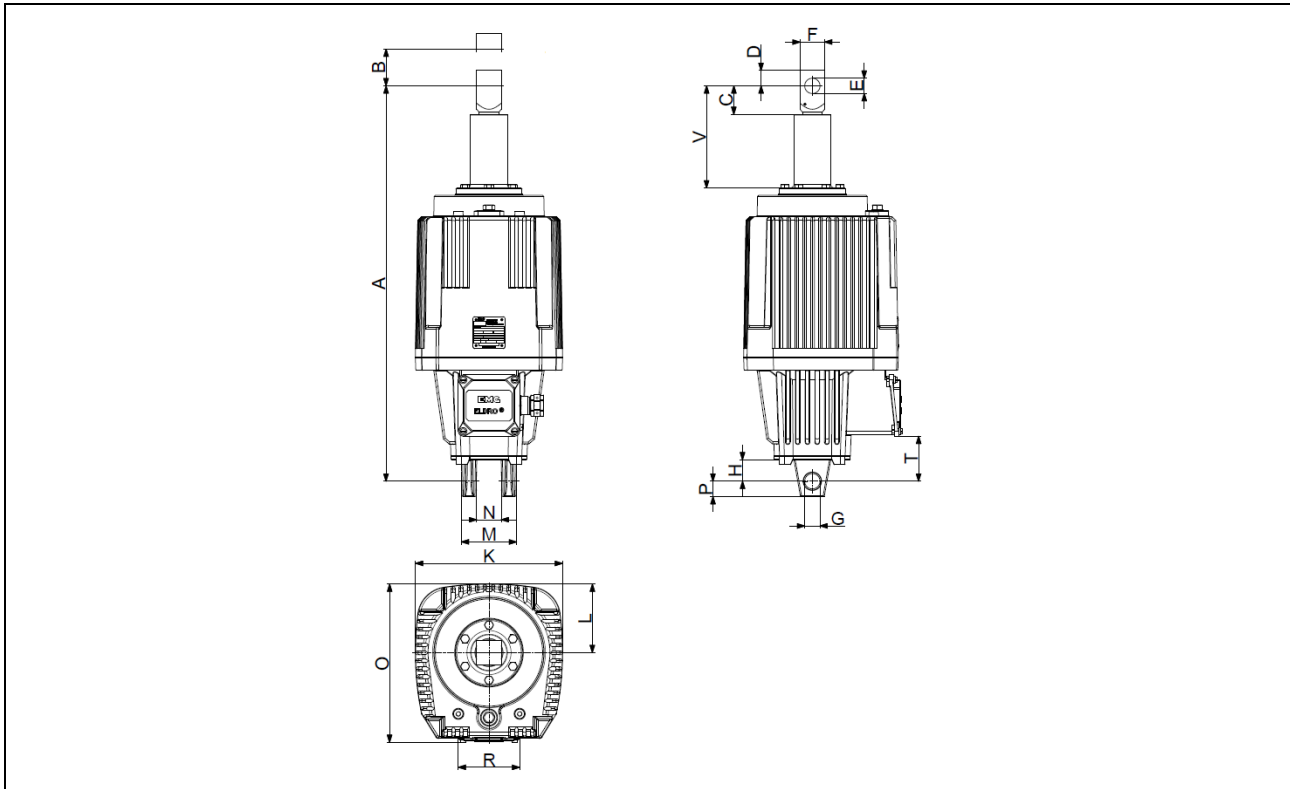
2) Tolerance +0.15 to +0.25

3.5 Airborne sound emissions

The A-rated emission sound pressure level for all ELDRO® thrusters is 55 dB (A). This value was determined using an integrated sound pressure level measuring unit in accordance with DIN 45633 under the following measurement conditions:

- The ELDRO® thruster (measurement object) ran continuously.
- The measurement object was on a table around 0.8 m above the ground.
- The measurement microphone was 1.6 m above the ground.
- The diagonal gap between the measurement microphone and the measurement object was 1 m.

3.6 Operating conditions

3.6.1 Ambient temperature

Deviations from the values specified in the following must be compensated for by suitable equipment and/or measures such as cooling units, heating, encapsulation, etc.

Table 20. Operating behaviour depending on the ambient temperature

Temperature range	Operating fluid	Technical statement
Standard range -25 °C to +50 °C	HL	The lifting times may extend by up to four times on cold thrusters. The lowering times remain unchanged.
Special range above 50 °C	Special operating fluid	The manufacturer must be contacted
Special range below -25 °C	HL	Only permissible when installed upright. Additional heating equipment (connection voltage 230 or 115 V) and the manufacturer must be contacted. The heating is connected in the junction box to a 9-pin terminal board via an additional M25x1.5 cable insert. The user must provide a temperature control thruster to control it. This must switch the heating on once the ambient temperature falls below -20 °C. The heating must not be switched on above +20 °C due to the risk of overheating.
Special range -35 °C to +40 °C	Special cold-resistant operating fluid	Heating not required

3.6.2 Air humidity

Up to 100 % air humidity is permitted if special measures are taken.

3.6.3 Aggressive ambient conditions

Special measures (special paint) are required for use in aggressive ambient conditions (e.g. salty ambient air).

3.6.4 Voltage and frequency tolerances

The permissible voltage tolerances in operation are $\pm 10\%$ at the measured power and measured frequency unless otherwise specified on the type plate.

The permissible frequency tolerance is $\pm 2\%$.

3.6.5 Installation height

The maximum permissible installation height is 1,000 m above sea level unless otherwise specified on the type plate.

4 Functional description

The ELDRO® electro-hydraulic lifting thrusters are manufactured as different types. These individual types can be merged as follows due to their common attributes.

ELDRO® type
ED120-40-286, ED120-40-400, ED120-50-286
ED220-50-272, ED220-50-286, ED220-50-314
ED300-50-370, ED300-50-380, ED300-50-385, ED300-50-445, ED300-100-493
ED500-60-370, ED500-20-400, ED500-50-400
ED500-50-435, ED500-60-435, ED500-70-435, ED500-100-452, ED500-100-515, ED500-120-515
ED800-25-458, ED800-50-458, ED800-60-458, ED800-70-450, ED800-75-458, ED800-120-530
ED1250-25-458, ED1250-60-458, ED1250-70-450, ED1250-75-458
ED1250-60-645, ED1250-120-705, ED1250-160-573, ED1250-160-705
ED1500-60-458, ED1500-60-645, ED1500-80-705, ED1500-120-573, ED1500-160-573, ED1500-160-705
ED1850-60-600, ED1850-160-700
ED2000-60-645, ED2000-70-705, ED2000-120-705
ED2500-40-549, ED2500-60-549, ED2500-60-645, ED2500-70-705, ED2500-80-645, ED2500-80-705, ED2500-125-660, ED2500-150-660, ED2500-160-705, ED2500-175-660
ED3000-60-645, ED3000-60-660, ED3000-70-705, ED3000-80-645, ED3000-80-660, ED3000-120-705
ED3500-50-825, ED3500-100-660, ED3500-120-660, ED3500-125-660

4.1 Mechanical layout

The ELDRO® thruster combines all structural elements of a complete hydraulic system in one structural unit. This comprises a three-phase asynchronous motor (direct current motor in the special version), a closed hydraulic system and the work cylinder with piston and lifting rod. The hydraulic system's operating fluid is used to generate the force.

4.1.1 ED120 / ED220

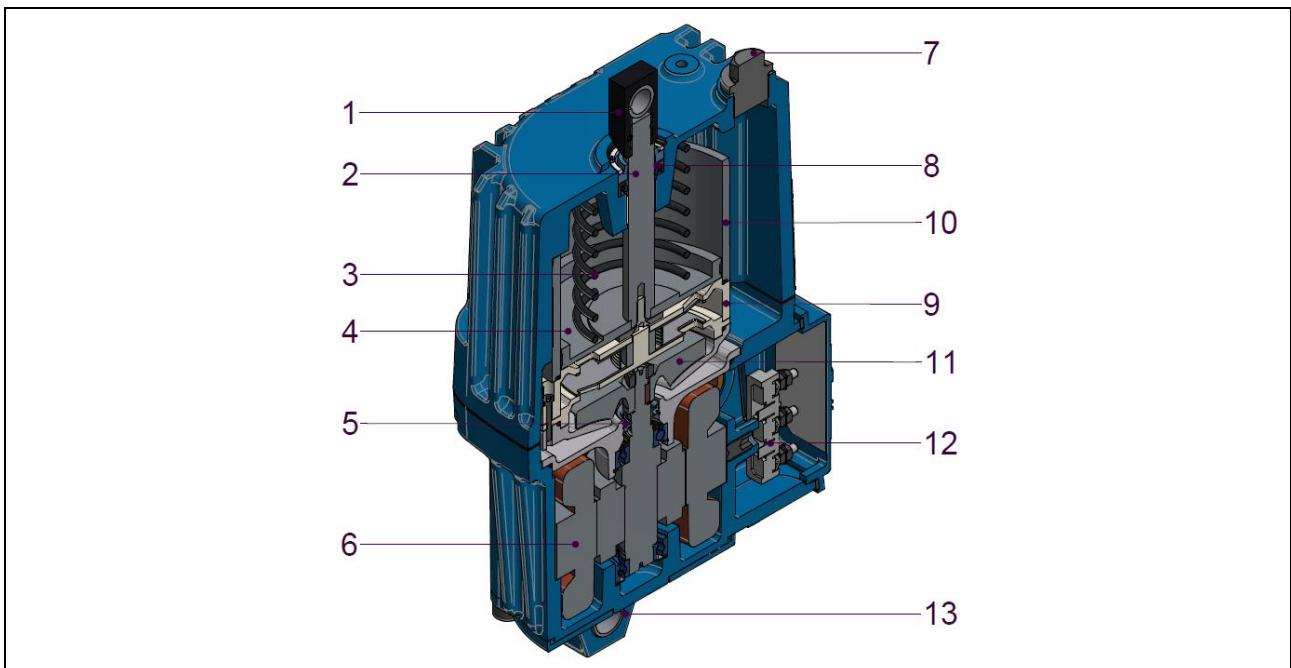

Figure 9. ELDRO® thruster ED120 / ED220 layout

1	Thrust shackle	8	Double seal to the hydraulic space
2	Piston rod	9	Lifting/lowering valve
3	Brake spring (c spring)	10	Hydraulic cylinder
4	Piston	11	Hydraulic pump
5	Motor shaft seal	12	Junction box
6	Two-pole three-phase asynchronous motor	13	Foot attachment
7	Oil filling opening		

4 Functional description

4.1 Mechanical layout



4.1.2 ED300 / ED500

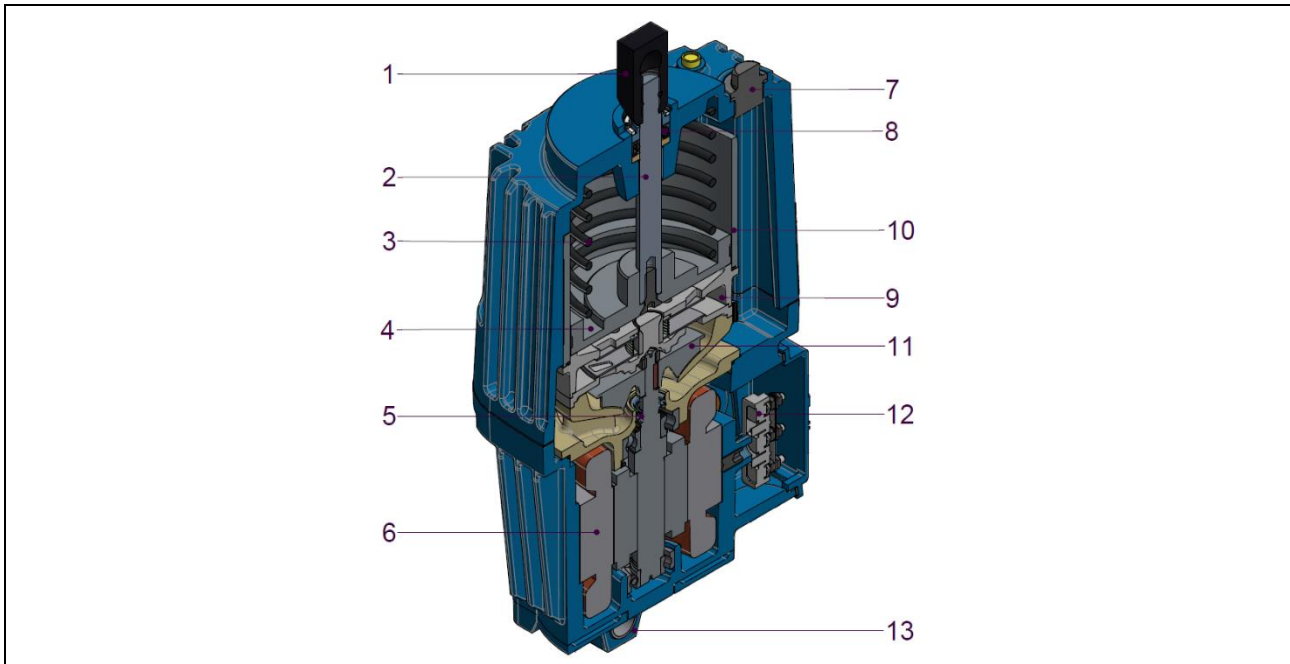

Figure 10. ELDRO® thruster ED300 / ED500 layout

- | | | | |
|---|---|----|------------------------------------|
| 1 | Thrust shackle | 8 | Double seal to the hydraulic space |
| 2 | Piston rod | 9 | Lifting/lowering valve |
| 3 | Brake spring (c spring) | 10 | Hydraulic cylinder |
| 4 | Piston | 11 | Hydraulic pump |
| 5 | Motor shaft seal | 12 | Junction box |
| 6 | Two-pole three-phase asynchronous motor | 13 | Foot attachment |
| 7 | Oil filling opening | | |

4.1.3 ED500 / ED1250

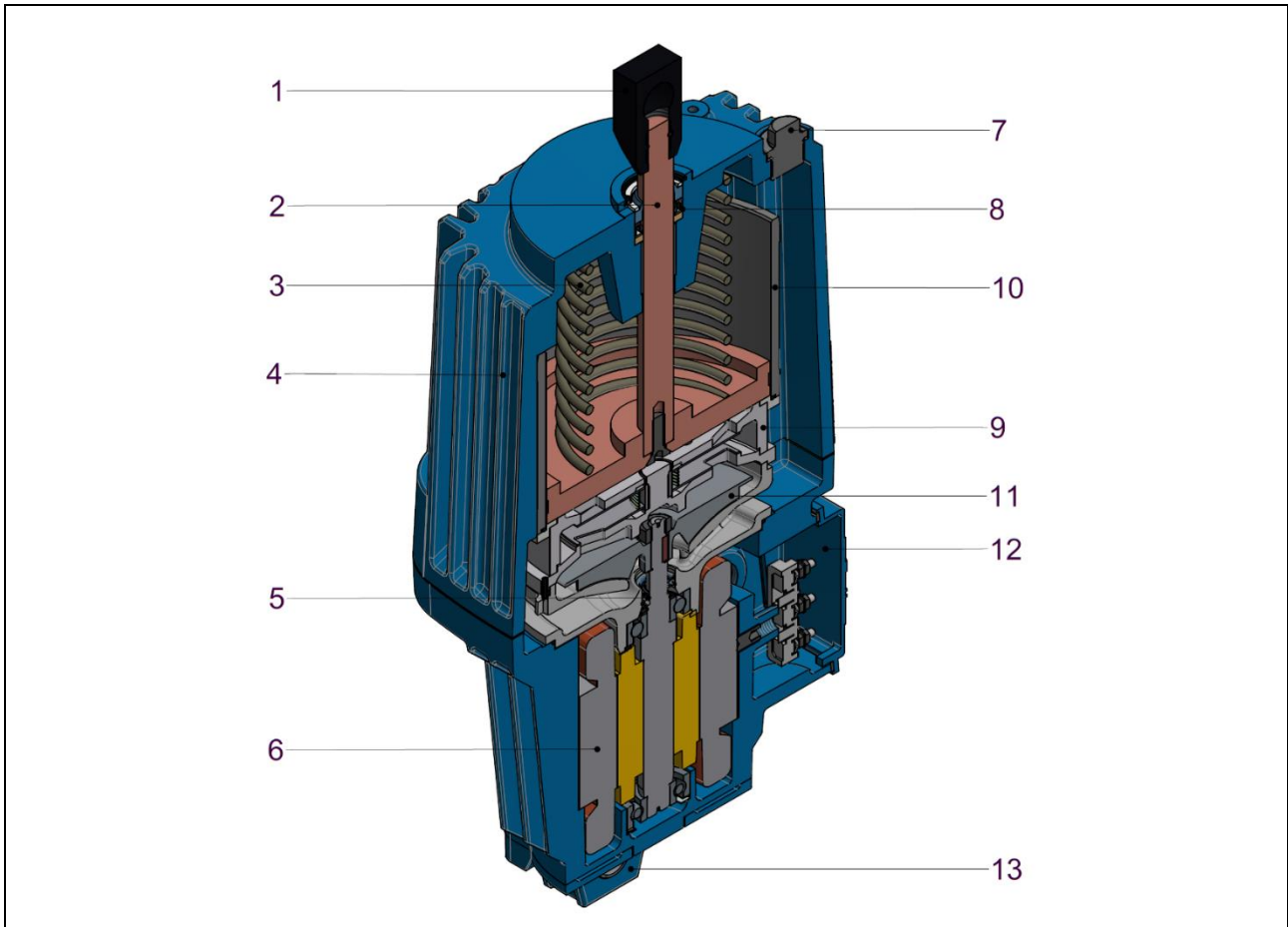

Figure 11. ELDRO® thruster ED500 / ED1250 layout

- | | | | |
|---|---|----|------------------------------------|
| 1 | Thrust shackle | 8 | Double seal to the hydraulic space |
| 2 | Piston rod | 9 | Lifting/lowering valve |
| 3 | Brake spring (c spring) | 10 | Hydraulic cylinder |
| 4 | Housing | 11 | Hydraulic pump |
| 5 | Double motor shaft seal | 12 | Junction box |
| 6 | Two-pole three-phase asynchronous motor | 13 | Foot attachment |
| 7 | Oil filling opening | | |

4.1.4 ED1250 / ED3500

The information was not yet available at the time of going to press. If necessary, contact the manufacturer.

4 Functional description

4.1 Mechanical layout



4.1.5 Rotatable thruster base

The rotatable thruster base can be adapted to the installation conditions by simple conversion (\Rightarrow Assembly and installation chapter, section Rotating the thruster base).

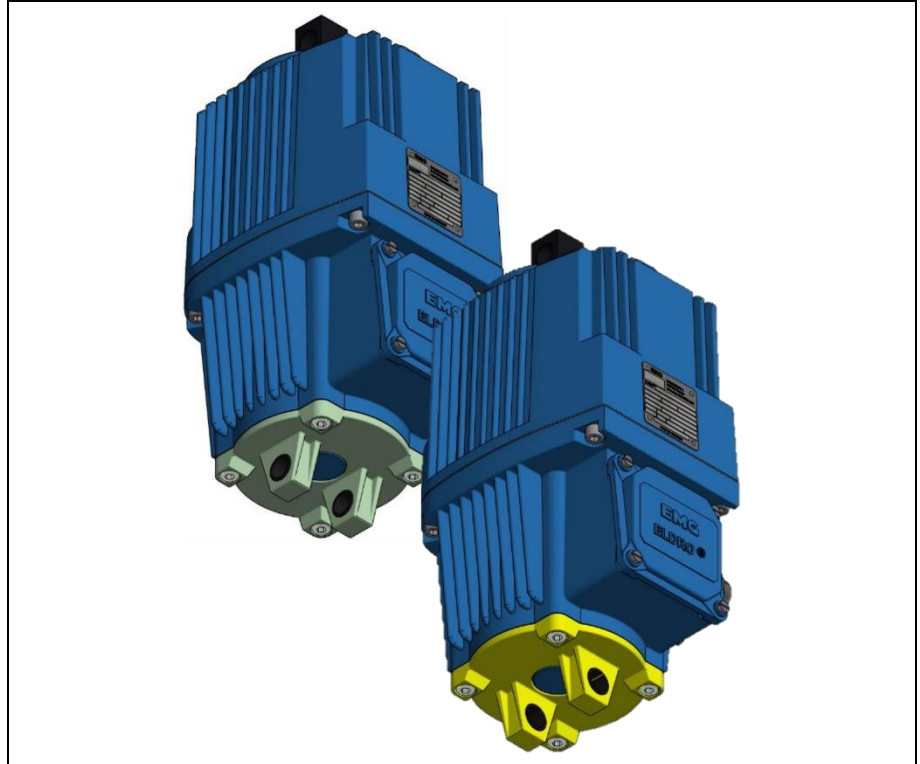

Figure 12. Rotatable thruster base

4.1.6 Cable gland

The ELDRO® thruster offers three possibilities to lead the cables into the junction box.

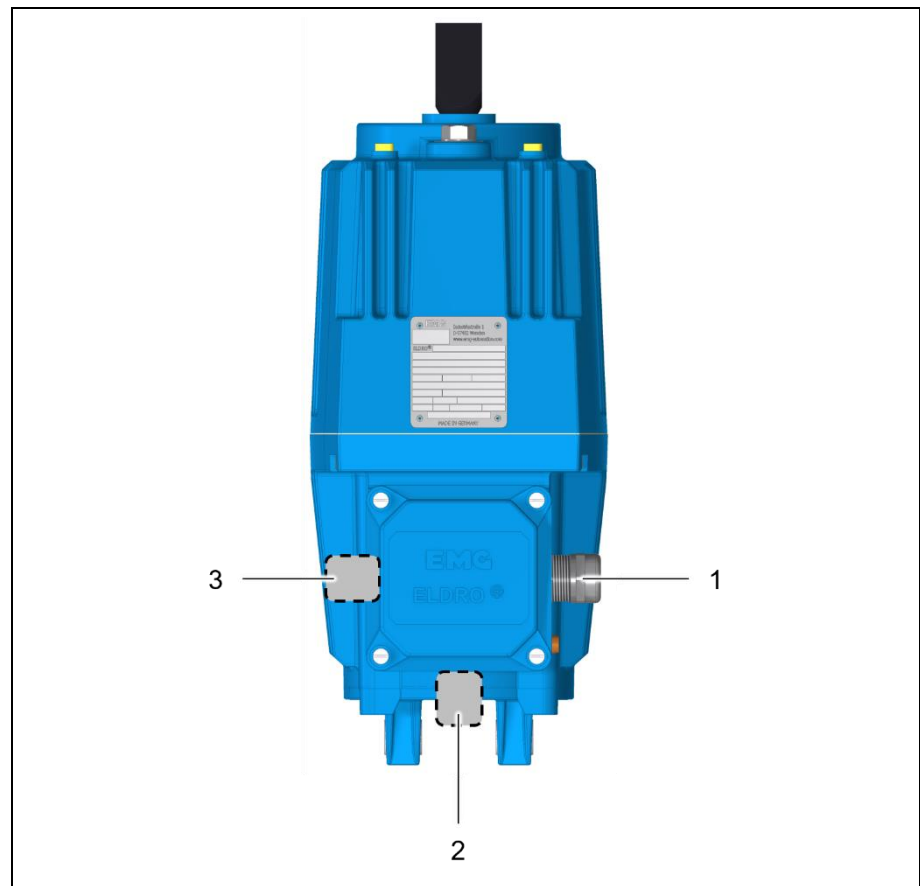

Figure 13. Cable gland

- 1 Cable entry on right
- 2 Cable entry at the bottom possible (on request from the manufacturer)
- 3 Cable entry on left possible (on request from the manufacturer)

4.2 Electrical equipment

A three-phase asynchronous motor is used as the drive (some special version also use direct current motors). The power supply is provided via screw terminals that are located in a junction box. There is an M25 x 1.5 cable infeed for cable diameters of 10 mm to 19 mm on the junction box.

4.2.1 Internal lift path monitoring

An integrated magnetic switch is used to monitor the following states:

- Brake "Open"
- Brake "Closed"
- Residual lift

When the ELDRO® thrusters are delivered, the magnetic switch is preset at the factory. The pressure strap must be aligned with the tension pin towards the front of the thruster. This is the only way to generate a switching signal when the piston moves in and out.

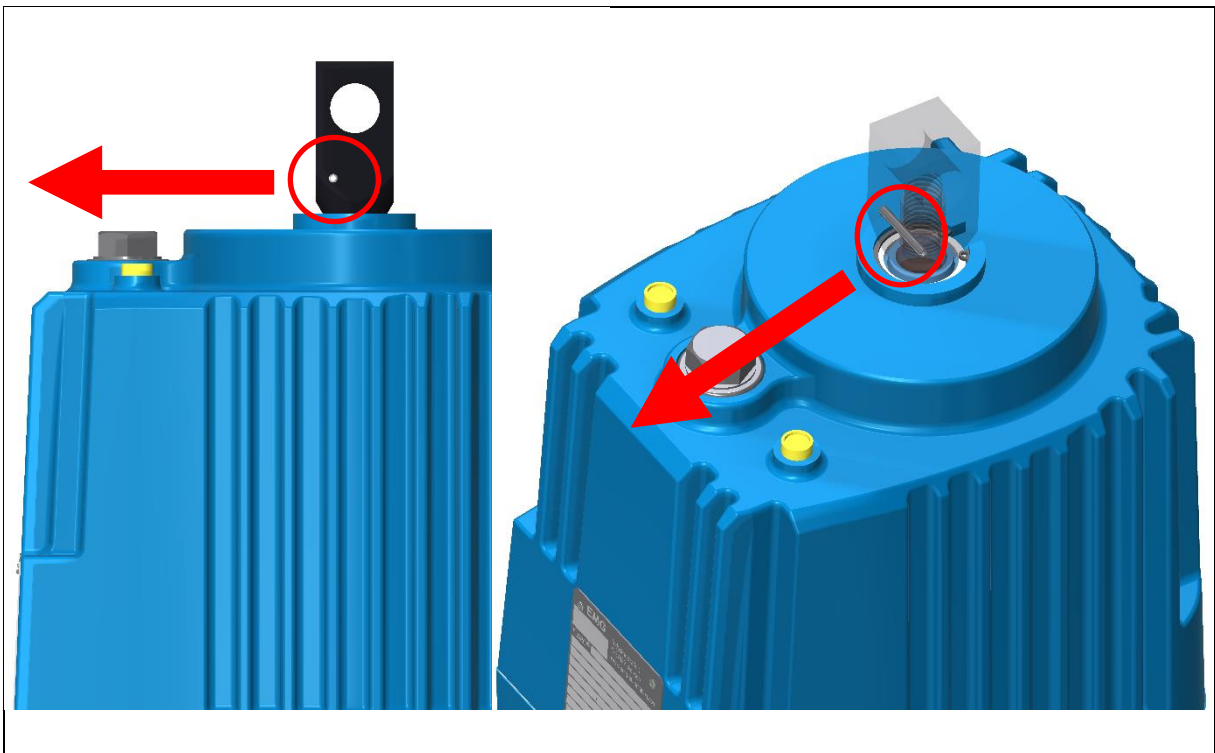

Figure 14. Pressure strap alignment with internal stroke path monitoring

4.2.2 Low temperature heating

The low temperature heating of the ELDRO® thrusters is designed as a heating rod:

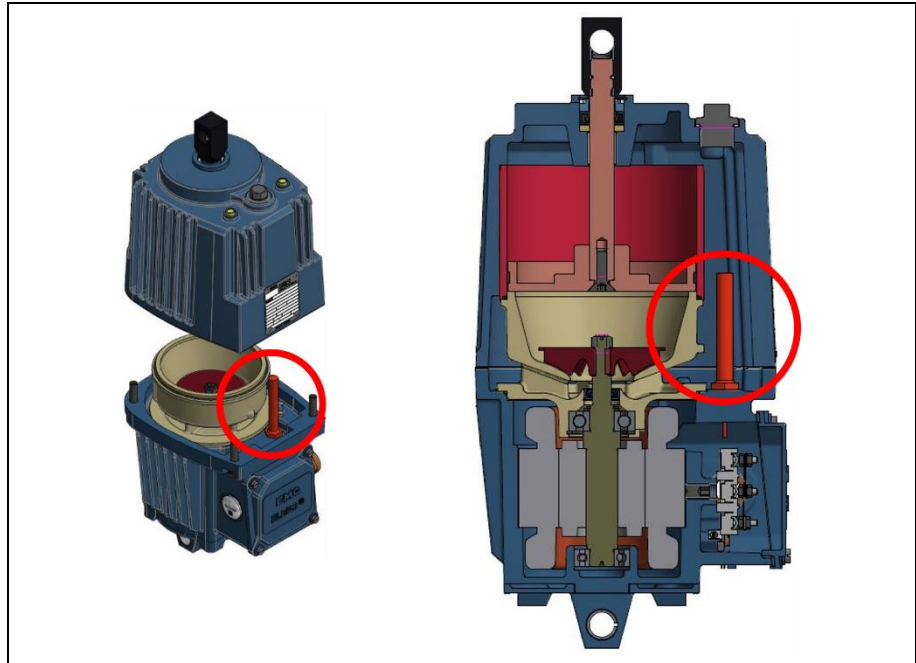

Figure 15. Heating rod

The heating rod is located directly in the oil. It is switched off automatically by a thermal switch in the junction box.

4.3 Functional description

The hydraulic pump driven by the motor conveys the hydraulic medium into the space below the piston. This generates hydraulic pressure that acts outwards via the piston and lifting rod.

The piston and lifting rod move backwards after the motor is switched off either due to a force acting from the outside (brake weight, brake spring) or due to the integrated reset spring. The lifting force that is available to the user of the ELDRO® thruster is therefore always the difference between the generated hydraulic force and any external or internal counterforce.

The lifting and lowering times depend on both the load and the viscosity of the hydraulic medium, which is in turn affected by the ambient and operating temperatures. In the versions with lifting, lowering or lifting and lowering valves, the setting/resetting speed of the lifting rod and therefore the lifting and lowering times can be adjusted infinitely within a specific range.

If the piston is in the limit position (e.g. in continuous mode S1), the motor's power consumption reduces due to hydraulic laws. This prevents the ELDRO® thruster overloading and a thermal protective switch is therefore not required.

5 Transport and storage

5.1 Transport



WARNING

The ELDRO® thrusters weigh between 10 and 70 kg

Risk of injury when lifting the load manually, risk of crushing due to load falling during transport.

- Use suitable lifting equipment (e.g. crane).
- Never remain below suspended loads.
- Use a transport aid (e.g. lifting carriage) with sufficient load bearing capacity.
- Wear safety shoes.
- When transporting ELDRO® units that are lifted by the pressure plate, make sure that the piston rod is pulled out of the lifting thruster. When lowering raised lifting thrusters, the piston rod retracts accordingly.



CAUTION

Falling ELDRO® thruster

Risk of injury due to a falling ELDRO® thruster during transport.

- Wear safety shoes.

INFORMATION

Do not damage the fastening eyes and the lifting rod when setting down. The lifting rod must be protected in a suitable way.

The ELDRO® thrusters are packed so that transport damage will not occur under normal transport conditions. The packaging requires corresponding labels.

The delivery must be checked for transport damage and completeness immediately upon receipt.

5 Transport and storage

5.1 Transport



If there is clearly visible transport damage, proceed as follows:

- Do not accept the deliver or accept it with reservations.
- Note the extend of the damage on the transport documents or on the carrier's delivery note.
- Declare the faults.

Declare every fault as soon as it is discovered. Claims for damage can only be made within the legal warranty period.

5.1.1 Transport sketch

Attach a suitable load carrying thruster to the attachment point to transport using lifting gear.

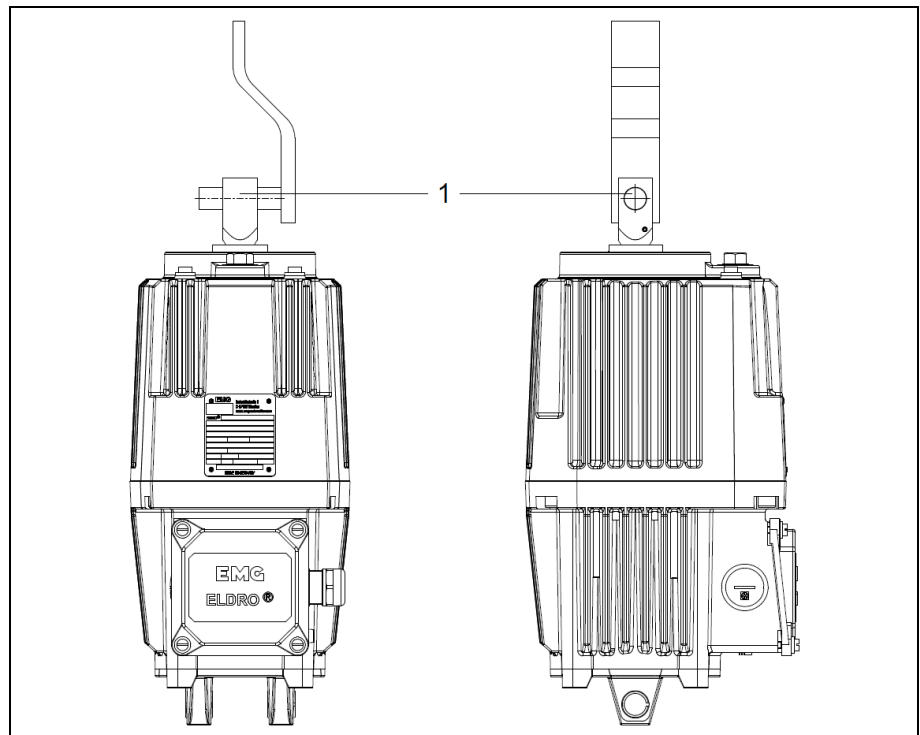

Figure 16. Attachment point

1 Attachment point

5.2 Storage

The ELDRO® thrusters can be transported or stored upright or lying down until commissioned. After storing for more than 6 months, we recommend storing the ELDRO® thrusters upright. Even though the thrusters are basically suitable for installation outdoors, we recommend taking protective measures against the effects of weather while storing.

INFORMATION

If stored for an extended period, the regulations for storage conditions and storage periods for rubber materials and moulded items must be observed with regard to sealing. Even when installed, the seals that were stored for too long lose their elasticity and therefore their full function.

6 Assembly and installation

The following safety regulations must be adhered to before beginning any work on ELDRO® thrusters:

- Ensure that the industrial system is shut down.
- De-energise the system.
- Safeguard the system to prevent it being switched on again.
- Test to ensure a de-energised state.
- Earth and short-circuit.
- Cover or isolate adjacent live parts.

6.1 Assembly

The ELDRO® thruster may only be assembled by specialists (e.g. industrial mechanics/electricians) with many years of experience.



WARNING

Cylinder movements

Risk of crushing between surrounding hindrances and the cylinder or connected components.

- When assembling, ensure sufficient free space to prevent crushing.
- Take alternative measures to safeguard this hazard point.



WARNING

Hot surface

During operation, the surface of the ELDRO® thruster can heat up to 100 °C. If there are components in the direct vicinity that are not designed for these temperatures (low ignition temperature), there is a danger of fire. Contact may cause burns.

- Pay attention to the high temperatures during planning and assembly (minimum distances, avoid heat accumulation).
- The ELDRO® thruster must be positioned so that it cannot be reached during operation.

 **CAUTION****The ELDRO® thrusters weigh between 10 and 70 kg**

Risk of injury when lifting the load manually.

- Use suitable lifting equipment (e.g. crane).
- Never remain below suspended loads.
- Use a transport aid (e.g. lifting carriage) with sufficient load bearing capacity.

 **CAUTION****Sudden power failure or switch-off due to any c springs, brake springs, brake weights that may be installed or due to other external influences**

Risk of crushing due to the lifting rod.

- Before removing the ELDRO® thrusters, the downstream drive must be secured, as the lifting rod retracts automatically.

INFORMATION

The lifting rod must not be damaged or contaminated (e.g. by paint as a result of painting the entire system). A failure to observe this will destroy the lifting rod.

INFORMATION

The fastening bolts on the foot hole and the lifting rod must be secured reliably to prevent them slipping out (e.g. using cotter pins).

INFORMATION

The ELDRO® thruster must not be subjected to any loads at an angle to its working direction. If installed upright, there must be no additional load beyond its own weight.



When replacing old ELDRO® thruster versions with thrusters with the current version, the manufacturer must be contacted due to the different installation dimensions.

6.1.1 Permissible installation positions

ELDRO® thrusters may be installed vertically, horizontally and in angled positions in accordance with the following illustration. The type plate must always be at the top. This is important, as the compensation space that is below the type plate must always be at the top.

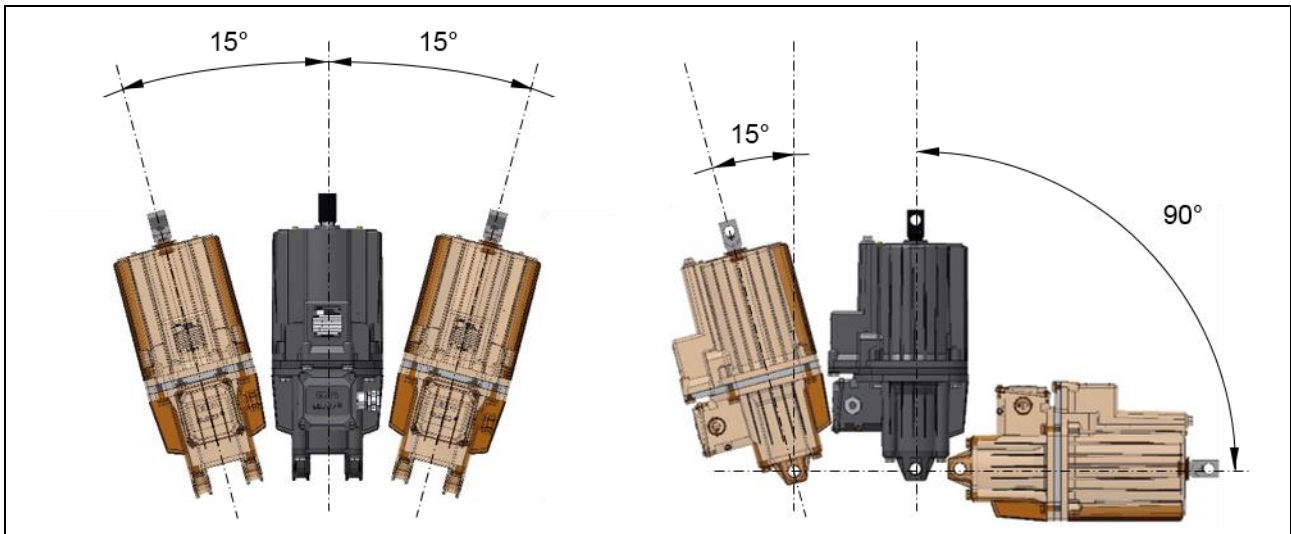

Figure 17. Permissible installation positions



If a horizontal installation position with the junction box arranged on the side or underneath is required due to the space available for example, the manufacturer must modify the ELDRO® thruster.

6.1.2 Installing the ELDRO® thruster

To attach the ELDRO® thruster, there are fastening eyelets on the motor housing and holes in the lifting rod, which can be used with suitable bolts to establish the connection to the equipment to be operated (e.g. brakes).

The diameter and length of the required bolts are specified in the dimension table (⇒Technical data chapter, Dimensions section).



When selecting or measuring the bolts (by the customer) the required pivoting ability of the ELDRO® thruster must be observed.

The ELDRO® thruster is installed in the following steps:

- Use lifting gear to move the ELDRO® thruster to the required installation location.
- Grease the bolt slightly in order to prevent it rusting tight.
- Insert the bolt into the foot hole.
- Insert the bolt into the thrust shackle hole.

INFORMATION

Both bolt axes must be parallel as otherwise, the lifting rod jams and the thruster's free power development is not guaranteed.

- Use cotter pins or similar to secure the bolts to prevent them slipping out.
- Check the oil level after assembly is complete.

6.2 Electrical connection



DANGER

Live components

Fatal electric shock or serious burns

- Work on live components may only be performed by electricians.
- When performing any work on electrical components, the five safety rules must be adhered to:
 - 1. Disconnect from the electrical supply
 - 2. Safeguard to prevent a restart
 - 3. Test to ensure a de-energised state
 - 4. Earth and short-circuit
 - 5. Cover or isolate adjacent live parts
- The earthing conductor must always be connected before all other cables.
- Electrical power may only be supplied once the earthing conductor is connected.

Standard requirements must be observed when connecting the EL-DRO® thruster.

Before connecting, it must be checked whether the mains voltage and the mains frequency correspond to the specifications on the type plate.

6.2.1 Junction box and terminal diagram

6-pin terminal board

Terminal diagram:

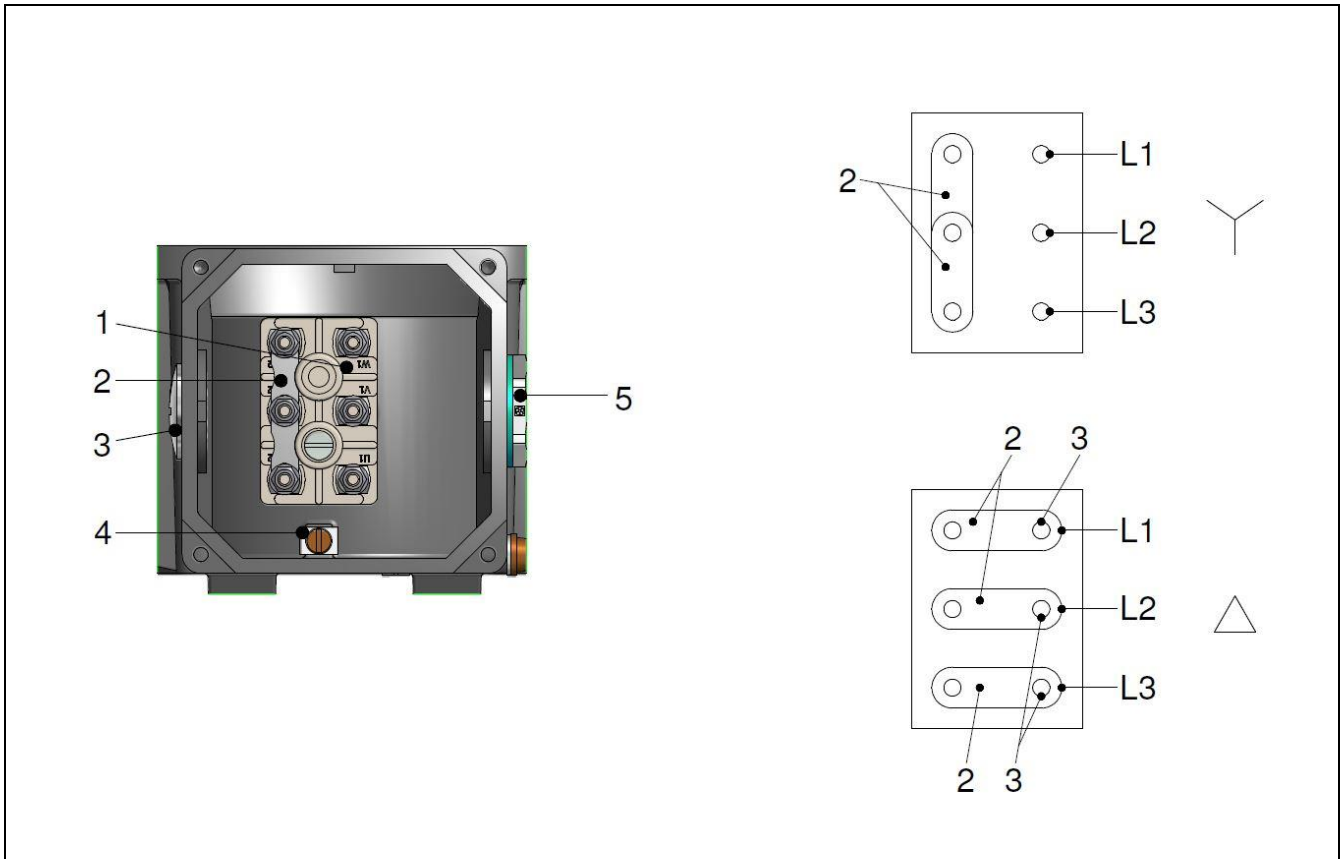

Figure 18. 6-pin terminal diagram

- 1 Connection terminals for the motor
- 2 Bridge
- 3 Blank plug
- 4 Earthing conductor terminal
- 5 Screwed connection M25-x-1.5

- Δ Delta connection
- Y Star connection (condition as delivered)

6 Assembly and installation

6.2 Electrical connection



9-pin terminal board with heating

Terminal diagram:

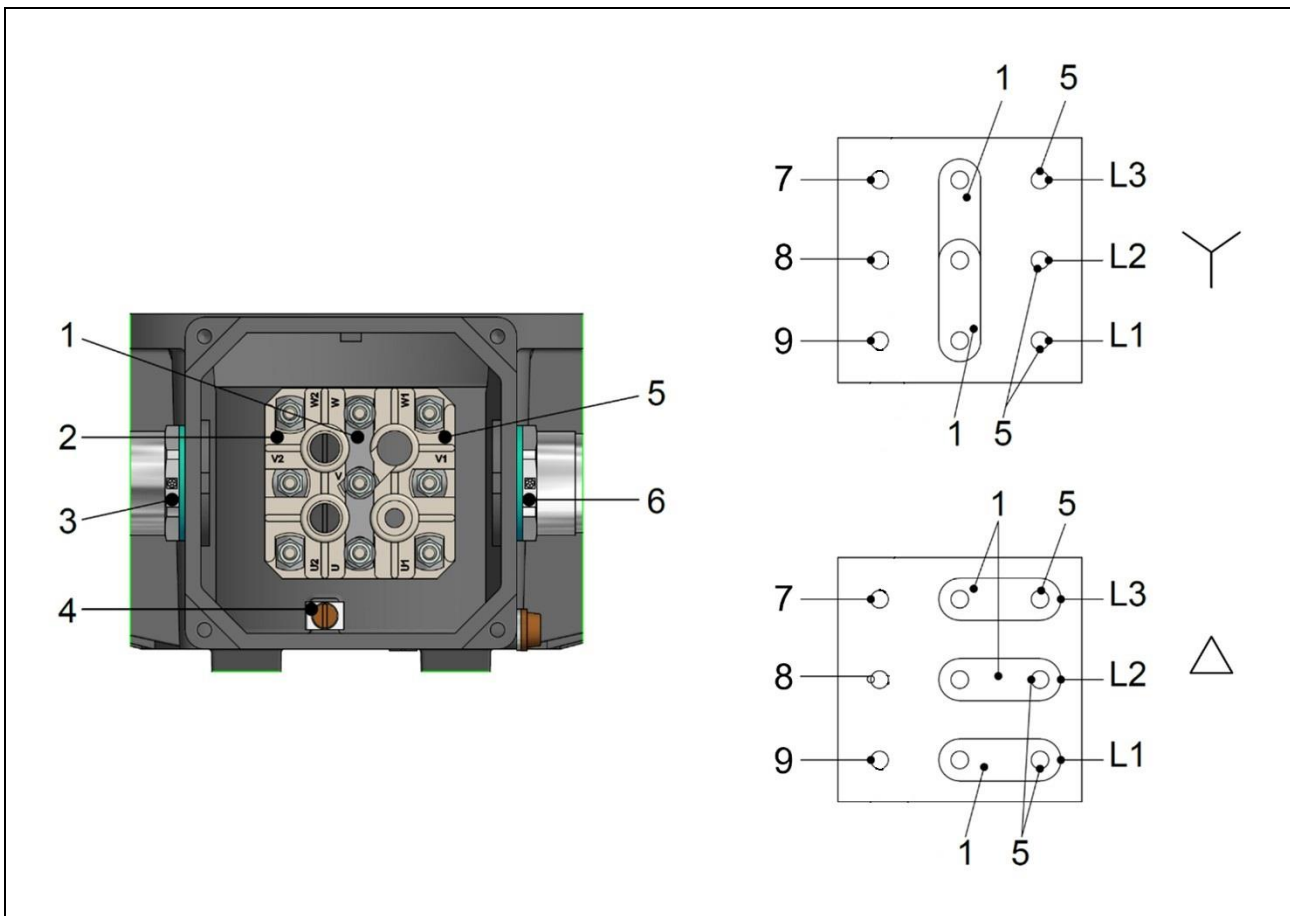

Figure 19. 9-pin terminal diagram with heating

- | | | | |
|---|--|---|--|
| 1 | Bridge | 5 | Connection terminals for the motor |
| 2 | Connection terminals for heating (120V/230V) | 6 | M25x1.5 screw connection for motor cable |
| 7 | L1 | | |
| 8 | - | | |
| 9 | N | | |
| 3 | M25x1.5 screw connection for heating cable | | Delta connection |
| 4 | Earthing conductor terminal | | Star connection (condition as delivered) |

9-pin terminal board without heating

Terminal diagram:

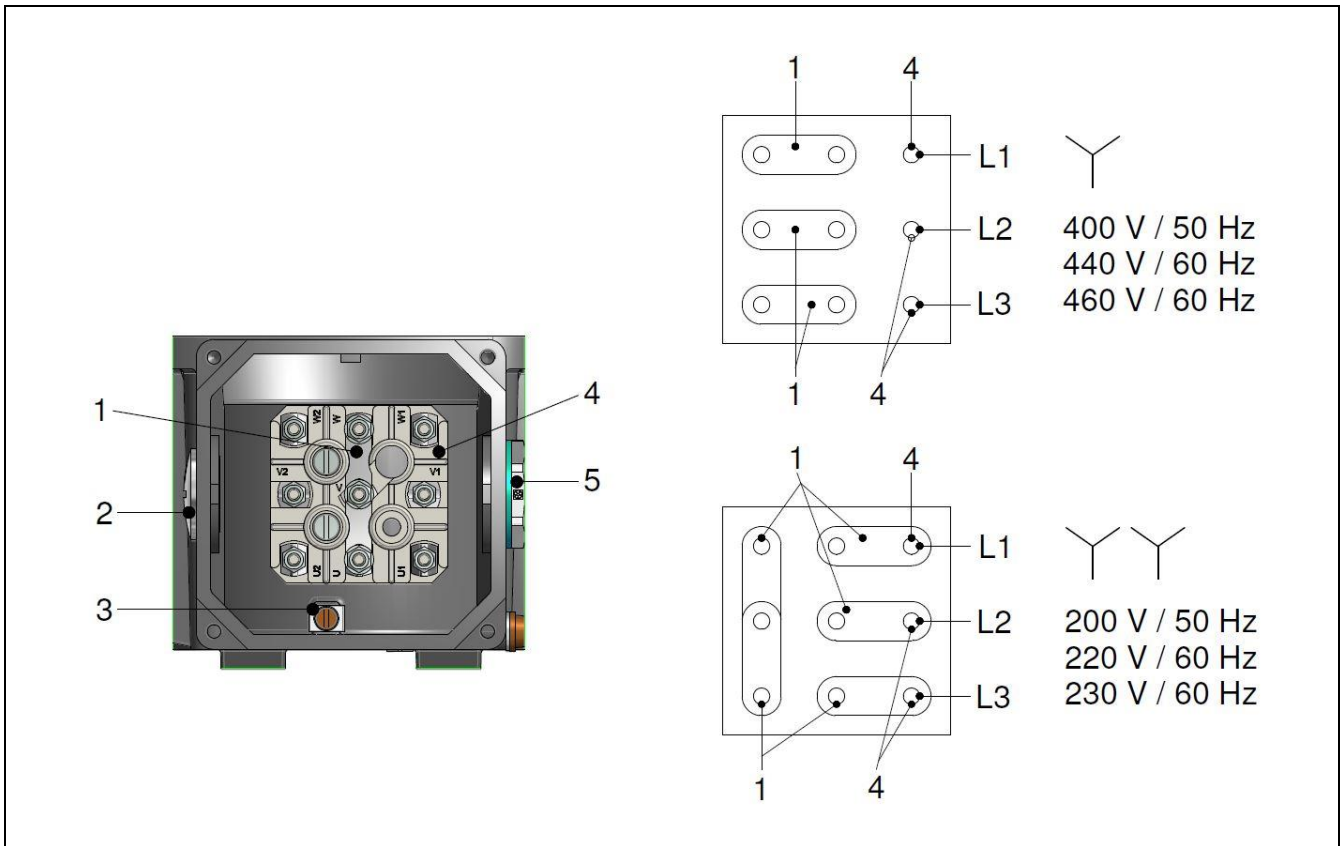

Figure 20. 9-pin terminal diagram without heating

- | | |
|--------------------------------------|--|
| 1 Bridge | 5 M25x1.5 screw connection for motor cable |
| 2 Blank plug | Y Star connection (condition as delivered) |
| 3 Earthing conductor terminal | YY Double star connection |
| 4 Connection terminals for the motor | |



If required, the motor can also be operated with a double star connection YY by reconnecting the bridges (2).

9-pin terminal board with Reed-contact

Terminal diagram:



Abbildung 21: 9-pin terminal diagram with Reed-contact

- | | | | |
|----|---|---|--|
| 1 | Bridge | 5 | Connection terminals for the motor |
| 2 | Connection terminals for Reed-contacts | 6 | M25x1.5 screw connection for motor cable |
| 2a | Contact 1 (above) | | |
| 2b | 24 V AC/DC (230 V on request) | | |
| 2c | Contact 2 (below) | | |
| 3 | M25x1.5 screw connection for Reed-contact cable | Δ | Delta connection |
| 4 | Earthing conductor terminal | Y | Star connection (condition as delivered) |

6.2.2 Earthing conductor connection

INFORMATION

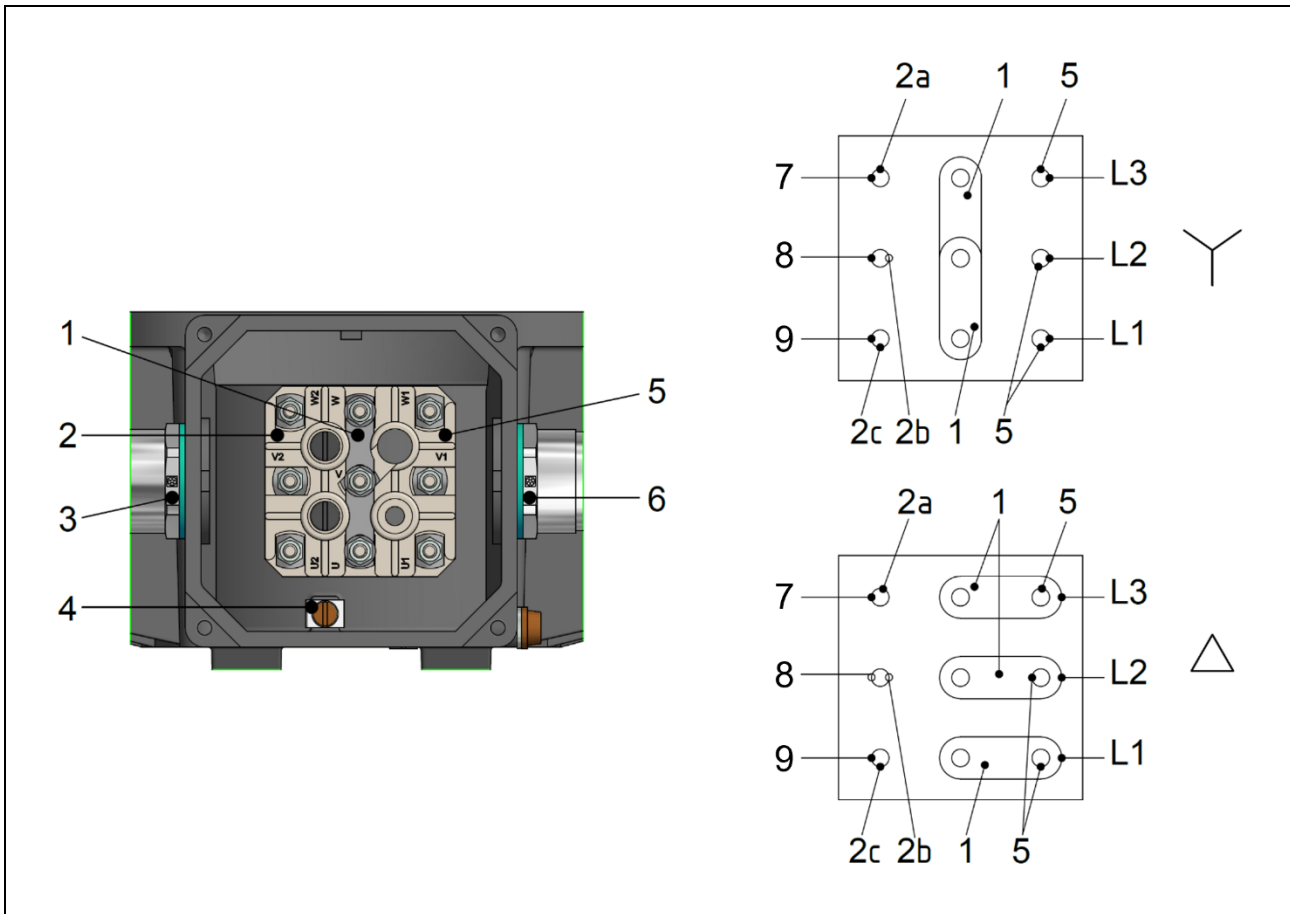
If the external earthing conductor connection is used, the thruster's pivoting ability and the surface temperature must be considered.

- The earthing conductor must always be connected before all other cables.

There is one earthing conductor in the junction box (⇒Junction box and terminal diagram section) and one in the immediate vicinity of the junction box on the outside of the ELDRO® thruster. The earthing conductor must be installed on the ELDRO® thruster in accordance with the applicable standards. The purpose of the earthing connector is to reduce the contact voltage in the event of coil or insulation damage to a safe amount and to switch the system off in conjunction with monitoring equipment. This can only be achieved by measuring the earthing conductor sufficiently, installing it properly and ensuring that it is intact.

6.2.3 Power supply connection

INFORMATION

Before connecting, check whether the mains voltage and the mains frequency correspond to the specifications on the type plate.

Always keep the junction box clean.

Check that the sealing elements on the junction box are intact and tight.

Always lock the junction box cover after connecting.

The M25 x 1.5 cable insert must be provided by the operating company properly in accordance with the IP protection class specified on the type plate.



Due to hydraulic laws, the motor's power consumption reduces when the piston has reached the limit position. This prevents overloading. A thermal protective switch is therefore not required. If a motor protection switch is used to safeguard the ELDRO® thrusters despite this, we recommend adjusting the thermal overcurrent trigger to 3 times the thruster current according to the type plate.

If using a quick lowering switch (capacitors) and a motor protection switch, the overcurrent trigger must be adjusted after consulting EMG Automation GmbH.

Electrical power may only be supplied once the earthing conductor is connected and can be provided as a fixed cable if the thruster is arranged stationary.

A pivoting arrangement requires a flexible cable. A minimum cable cross section of 1.5 mm² must be provided for all thruster sizes. The connection terminals permit a maximum cable cross section of 2.5 mm². When selecting the cables, the ambient conditions (e.g. temperature, humidity) at the installation location must also be considered.

The junction box is equipped with an M25 x 1.5 cable infeed (cable diameters from 10 mm to 19 mm).

- The supply lines are always connected in accordance with the switch diagrams on the inside of the junction box cover (⇒Junction box and terminal diagram section).
- Only connection cables with a temperature approval of at least 110°C may be used.



Unless ordered differently, all ELDRO® thrusters are wired for a star connection as delivered from the factory. If required, the user can reconnect the bridges (⇒Junction box and terminal diagram section) to also operate the motors in delta connection. The motor's phase sequence and therefore its direction of rotation do not matter.

6.2.4 ELDRO® thrusters with additional heating

INFORMATION

To control the additional heating, the operating company must provide a temperature control unit that switches the heating on below an ambient temperature of -20 °C and switches it off again above -20 °C. The heating must not be switched on above -20 °C due to the risk of overheating.

ELDRO® thrusters with integrated additional heating (observe the supply voltage) are connected in accordance with the terminal diagrams located inside the junction box cover (⇒Junction box and terminal diagram section). The cables for the motor's power supply are guided via the M25 x 1.5 screw connection. The heating's power supply is provided via the second M25 x 1.5 screw connection on the junction box.

Temperature measurement points

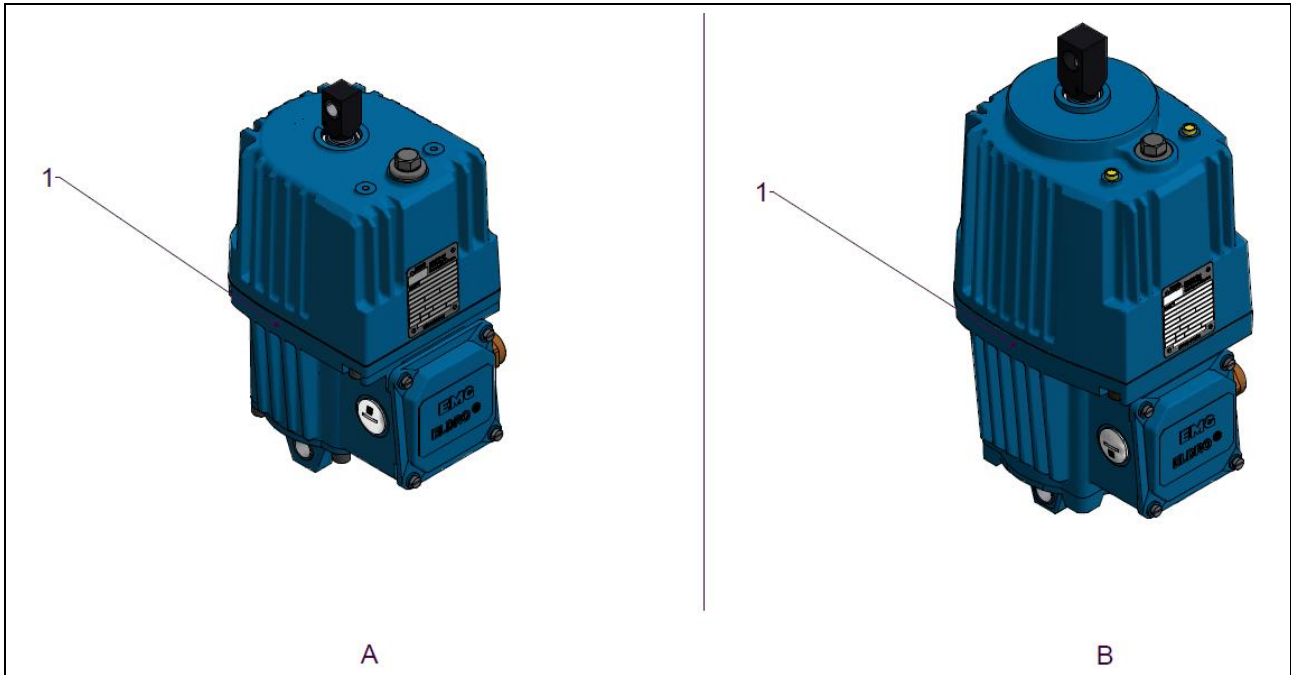

Figure 22. Temperature measurement points

A Type ED120 / ED220

1 Temperature measurement point

B Type ED300 / ED500...

6.3 Adjusting the valves



In the condition as delivered, the ELDRO® thrusters are set to 5 seconds of setting time and resetting time. The setting times depend on the temperature and must be adjusted when the machine is at operating temperature.

The versions with lifting and/or lowering valves enable the lifting rod's set or reset speed (setting or resetting time) to be adjusted infinitely within a specific range. The type designation on the type plate specifies whether an ELDRO® thruster is equipped with valves (see type plate; ⇒ Type designation and type key section).

Examples for the version with valves:

- Lowering valve (S): e.g. ED300-50-370 S
- Lifting valve (H): e.g. ED500-60-435 H
- Lifting and lowering valve (HS): e.g. ED1250-60-645 HS

6.3.1 Adjustment screw installation location



Figure 23. Adjustment screws H and S

- 1 Adjustment screw H (lifting time)
- 2 Adjustment screw S (lowering time)

Adjustment screw H for the set time (lifting time) is located to the left of the type plate below a sealing plug.

Adjustment screw S for the reset time (lowering time) is located to the right of the type plate and is also below a sealing plug.

6.3.2 Changing the set time and the reset time

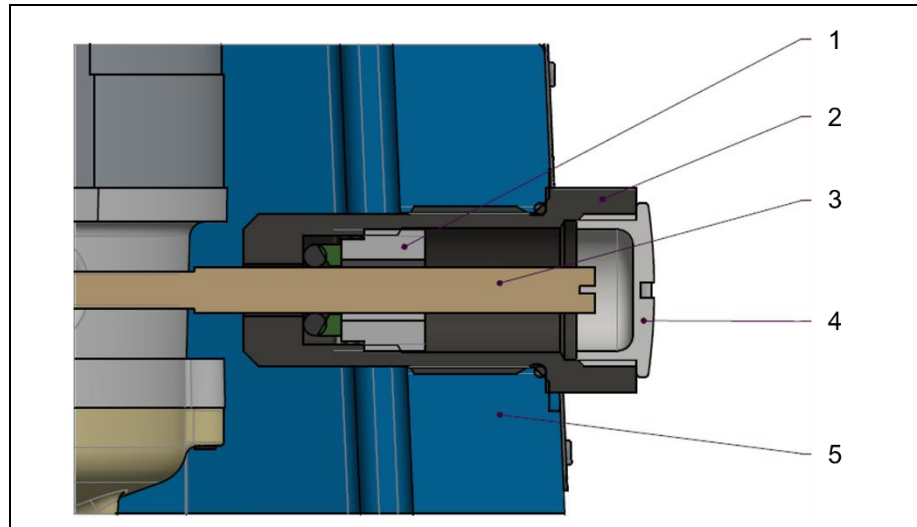

Figure 24. Lifting/lowering valve adjustment parts

- 1 Slotted nut
- 2 Threaded connection
- 3 Adjustment pin
- 4 Sealing plug
- 5 Housing



Turning the adjustment pin (3) clockwise increases the lifting or lowering time.

Turning the adjustment pin (3) anticlockwise reduces the lifting or lowering time.

INFORMATION

When turning anticlockwise, the adjustment pin (3) must not be turned out further than the end of the threaded connection (2).

Release the slotted nut (1) by a maximum of a quarter turn due to the risk of losing leak-tightness.

The slotted nut must be re-tightened to hand tight after adjusting the set or reset time.

- Unscrew the sealing plug (4)
- Turn the adjustment pin (3) to set the required set or reset time
- Screw the sealing plug (4) in

6.4 Rotating the thruster base

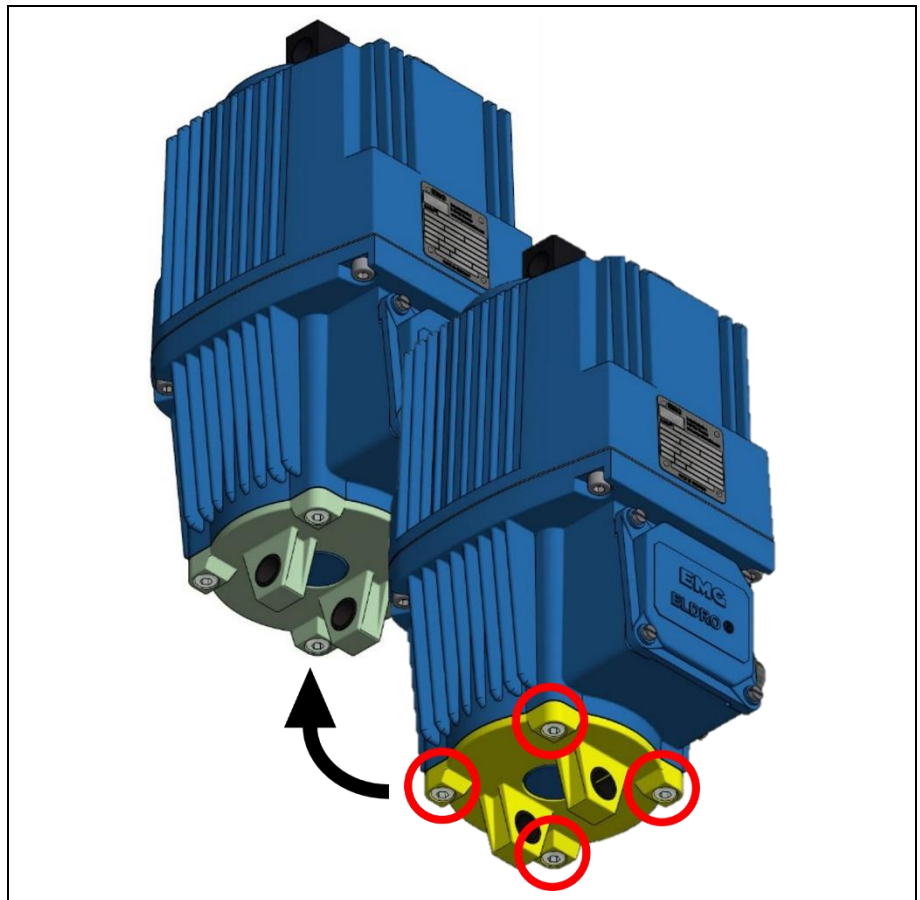

Figure 25. Rotating the thruster base

⇒ The ELDRO® thruster is detached

1. Loosen the four screws on the thruster base, remove them and store them for reuse
2. Remove the thruster base, turn it and put it back on again
3. Screw the four screws on the thruster base back in and tighten them to a torque of 20 Nm

6.5 Completing assembly

After completing assembly, check that the earthing conductor system is consistent.

7 Notes on operation



WARNING

ELDRO® thrusters can reach housing surface temperatures of up to 100 °C in continuous mode S1 or in switching mode S3

Risk of burns on the housing surface

- Avoid touching the housing surface during operation. This must be ensured by the positioning of the ELDRO® thruster. If this is not possible, suitable marking must be used.
- Wear heat-proof protective gloves.



WARNING

Component failure

There is the risk of individual components breaking when operating the lifting thruster. The lifting force failure can pose subsequent hazards.

- The operating parameters must be adhered to.
- The ELDRO® thruster must be installed so that no forces can be applied at an angle to the working direction.
- The fastening bolts on the thrust shackle and the foot attachment must be secured to prevent them moving inadvertently (e.g. using locking pins).
- Make sure that the axes are parallel.



WARNING

Lifting rod movements

Risk of crushing between surrounding hindrances and the lifting rod or connected components due to the lifting rod retracting automatically due to the reset spring of the hydraulic pressure fails or the power supply is interrupted.

- Switching the motor off returns the lifting rod to the limit position.
- When assembling, ensure sufficient free space to prevent crushing or take other measures to safeguard the hazard point.
- Before removing the ELDRO[®] thruster, the connected unit such as the brake must be secured to prevent movement.



WARNING

Hot surface

Severe injuries to the body and limbs due to burns on contact with the hot housing surface.

- Avoid touching the surface of the housing during operation. This must be ensured by the positioning of the ELDRO[®] thruster. If this is not possible, suitable marking must be used.
- Wear heat-proof protective gloves.

Never operate the ELDRO[®] thruster with electrical connections that are faulty or not ready for operation.

The junction box must always be locked. Access must only be granted to authorised staff who have received corresponding training and safety briefings.

If there are power supply faults, switch the ELDRO[®] thruster off immediately.

7.1 Checking the operating conditions prior to starting up

INFORMATION

When delivered from the factory, the junction box has a small bag (silica gel) in order to catch any moisture that may occur.

This small bag (silica gel) must be removed prior to commissioning.

- The ELDRO® thruster is assembled and connected according to regulations (⇒Assembly and installation section).
- The permissible voltage and frequency tolerances are adhered to (⇒Type plate).
- The ELDRO® thruster is filled with the operating fluid prescribed for the usage conditions (⇒ Technical data chapter, Ambient temperature and installation height section) and for the version, and has the required fill level (⇒Maintenance chapter, Operating fluid section).
- The ELDRO® thruster is protected against contamination.
- The fastening bolts on the thrust shackle and the foot attachment are secured to prevent them moving inadvertently (e.g. using locking pins).
- The axes are parallel.

8 Help with malfunctions

If used as intended, no typical malfunctions can occur on the ELDRO® thruster.

However, malfunctions can occur due to wear or misuse. Malfunctions on the ELDRO® thruster may only be rectified when the system is stopped, disconnected from the power supply and the movements have come to a standstill.

Observe the Assembly and Disassembly chapters for information on troubleshooting.

8.1 Faults and troubleshooting

Table 21. Faults and troubleshooting

Fault	Possible cause	Measure
ELDRO® thruster does not lift	Motor not running: Supply line interruption	Search for the interruption and rectify
	Motor not running: Switched off by trigger, e.g. motor protection switch	Check the motor protection switch and fuse elements
	Motor not running: Cable connections have poor contact	Clean corroded contacts
	Motor not running: Rotor is blocked in the stator within the bearing or close to the running wheel (pump)	Replace the thruster and send to the manufacturer for repair
	Motor not running: Too great an external load in addition to the brake and reset spring	Adjust the load on the thruster
	Lack of operating fluid	Top up the operating fluid
	Lifting rod jammed from the outside	Rectify the jam/twisting or lateral forces in the thrusters to be driven
The ELDRO® thruster lifts slowly, hesitantly, jerkily	Thruster loaded too heavily: Too great an external load in addition to the brake and reset spring	Adjust the load on the thruster
	Lifting rod jammed from the outside	Rectify the jam/twisting or lateral forces in the thrusters to be driven
	Supply line interruption (two-phase operation)	Search for the interruption and rectify

Table 21. Faults and troubleshooting

Fault	Possible cause	Measure
The ELDRO® thruster lifts slowly, hesitantly, jerkily	Air in the pump circuit	Actuate the thrusters a few times when stopped and top up the operating fluid if required
		Check the thruster's installation position and version
	Lack of operating fluid	Top up the operating fluid
Operating fluid escapes	On the lifting rod seal	Replace the thruster and send to the manufacturer for repair
	On the filling screw	Check the sealing ring, tighten the filling screw to a maximum of 65 Nm
	At the separation level between the hydraulic housing and the motor housing	Tighten the screw connection to a maximum of 53 Nm
	On the motor housing or operating fluid in the junction box	Replace the thruster and send to the manufacturer for repair
Rattling, metallic noise	Ball bearing damaged	Replace the thruster and send to the manufacturer for repair
Motor protection switch or fuse elements tripped	Short-circuited coil, phase leakage or short circuit	Check the motor's resistors and insulation, replace the thruster and send to the manufacturer for repair if required
Increased current consumption, cause	Between two phases: Short-circuited coil	Measure the resistance, replace the thruster and send to the manufacturer for repair if required
	Between all phases: Rotor is grinding or stuck	Replace the thruster and send to the manufacturer for repair

9 Maintenance

Maintenance work on the ELDRO® thruster may only be performed when:

- the system is stopped
- the system has been disconnected from the power supply and secured to prevent a restart
- the movements have come to a standstill
- the ELDRO® thruster has cooled off.

Maintenance work may only be performed by instructed specialists (maintenance staff).

9.1 Maintenance tasks



WARNING

Hot surface

Stored residual heat poses a risk of burns if you touch the housing surface

- ELDRO® thrusters can reach housing surface temperatures of up to 100 °C in continuous mode S1 or in switching mode S3.
- The ELDRO® thruster must cool off before starting maintenance work.
- Wear heat-proof protective gloves.



WARNING

Spraying hydraulic oil

Risk of injury (e.g. face and eyes) due to spraying hydraulic oil

- When integrating the thruster into the overall system, a disconnecting switch or comparable device must be provided to ensure that all poles of the ELDRO® thruster can be disconnected from the power supply.
- The ELDRO® thruster must be secured to prevent a restart before opening.
- Only turn the filling screw slowly.
- Only specialists are permitted to unscrew and remove the filling screw.

**WARNING****Pre-tensioned reset spring**

Risk of injury when opening the ELDRO® thruster due to the pre-tensioned reset spring.

- Never attempt to open the ELDRO® thruster in order to access the reset spring.
- The ELDRO® thruster may only be opened by instructed specialists with corresponding training and special tools (e.g. disassembly tools for thrusters with c springs).

**WARNING****Lifting rod movements**

Risk of crushing between surrounding hindrances and the lifting rod or connected components due to the lifting rod retracting automatically due to the reset spring of the hydraulic pressure fails or the power supply is interrupted.

- Switching the motor off returns the lifting rod to the limit position.
- Before removing the ELDRO® thruster, the connected unit such as the brake must be secured to prevent movement.

9.1.1 Operating fluid

ELDRO® thrusters are delivered from the factory with the EMG operating fluid that depends on the usage conditions and the required version. Specify the EMG operating fluid type that was filled in on the type plate.

The EMG operating fluids are tuned to the components used for the ELDRO® thrusters and ensure seal compatibility.

INFORMATION

Observe the safety data sheet.

The same type of EMG operating fluid that is already in the ELDRO® thruster must always be used to top up.

Using an incorrect operating fluid can reduce the ELDRO® thruster's performance significantly so that the specified thruster properties are no longer reached.

The filling quantities listed in the following table refer to basic thrusters. Missing information was not yet available at the time of going to press. If necessary, contact the manufacturer.

Table 22. Fill quantities for operating fluid

ELDRO® type	Litres	ELDRO® type	Litres
ED120-40		ED2500-80, ED2500-125, ED2500-150	
ED120-50		ED2500-160, ED2500-175	
ED220-50		ED3000-60, ED3000-70	
ED300-50, ED300-60, ED300-100	2.3	ED3000-80, ED3000-120	
ED500-50, ED500-60, ED500-70	2.3	ED3500-50, ED3500-60, ED3500-70	
ED500-100, ED500-120		ED3500-80, ED3500-100	
ED800-25, ED800-50, ED800-60		ED3500-120, ED3500-125	
ED800-70, ED800-75, ED800-120			
ED1250-25, ED1250-60, ED1250-75			
EDED1250-120, ED1250-160			
ED1500-60, ED1500-80			
ED1500-120, ED1500-160			
ED1850-60, ED1850-160			
ED2000-60, ED2000-70, ED2000-120			
ED2500-40, ED2500-60, ED2500-70			

ELDRO® thrusters are filled with EMG operating fluids (hydraulic oil) in class HL10 DIN 51524 for the temperature range of between -25 °C and +50 °C when delivered. Special operating fluids are required for other temperature ranges (contact the manufacturer).

9.1.2 Checking the operating fluid



WARNING

Hot operating fluid

Risk of burns due to hot oil plumes when opening the filling screw when at operational heat.

- The operating fluid may only be checked, topped up or drained when switched off and cool.
- The ELDRO® thruster may only be opened at a maximum temperature of 40 °C.

INFORMATION

If not filled sufficiently, the thruster does not develop the full lifting force.

If overfilled, the thruster's internal pressure is impermissibly high.

The ELDRO® thrusters are filled correctly if the operating fluid level reaches the lower edge within the filling opening when the thruster is upright and the lifting rod is retracted.



The ELDRO® thruster must stand upright. Even a slight inclination falsifies the level test!

Observe the disassembly instructions if the ELDRO® thruster is not installed upright (⇒Disassembly chapter).

- Place the ELDRO® thruster upright.
- Remove the filling screw from the filling nozzle.

- Check the fill level according to the ELDRO® type and top up if required.

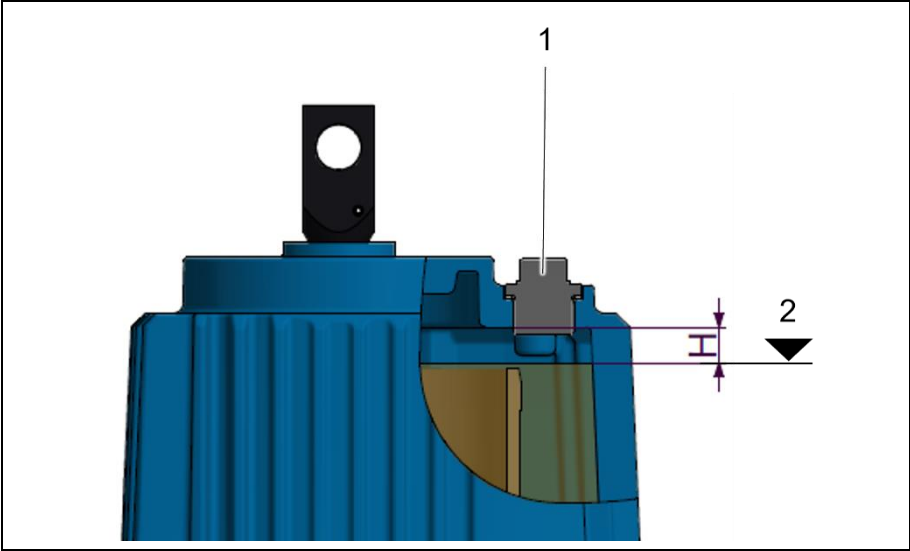

Figure 26. Operating fluid fill height

- 1 Filling nozzle
- 2 Operating fluid fill height
- H Distance value (type-dependent)

The following table contains the distance value H for different ELDRO® thruster types. Missing information was not yet available at the time of going to press. If necessary, contact the manufacturer.

Table 23. ELDRO® thruster type / Distance value H

ELDRO® thruster type	Distance value H in mm

Topping up the operating fluid

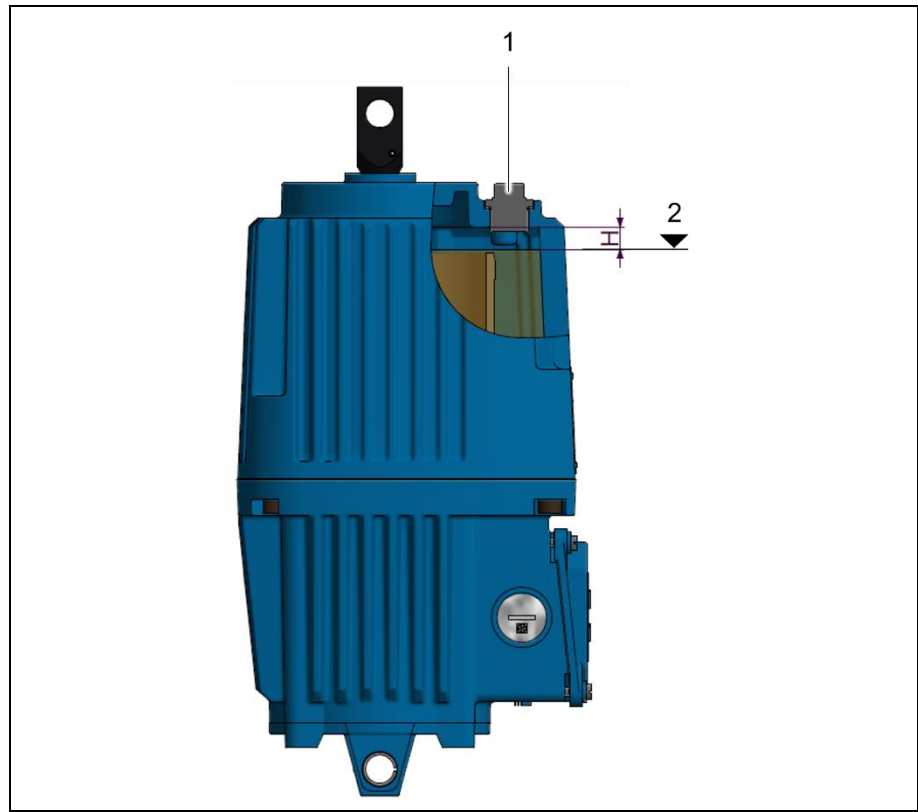

Figure 27. Topping up the operating fluid

- 1 Filling nozzle
- 2 Filling height

- Fill the ELDRO® thruster with operating fluid up to distance value H to the filling nozzle bottom edge. Perform several lifting movements while doing so in order to prevent air entering the system.
- Check the fill level again and top up if required.
- Close the filling screw and, if present, the overflow screw tight (tightening torque: 65 Nm).
- Return the ELDRO® thruster to its original installation position (⇒Assembly chapter).

9.1.3 Seals

The ELDRO® thruster must be checked for leaks at least once per year.

9.2 Maintenance schedule

Table 24. Maintenance log for ELDRÖclassic® lifting thrusters

ELDRO® New Generation			
Serial number			
System ID			
Classification according to section 3.1 (table 1)	Low requirements	Standard	Higher requirements
	<input type="checkbox"/>	<input type="checkbox"/>	<input type="checkbox"/>

Test object	Test interval according to classification			Test performed	Test passed	Evaluation / measured values
	Low requirements	Standard	Higher requirements			
Cleaning	as required	as required	as required	<input type="checkbox"/>	<input type="checkbox"/>	
Test run	Every six months			<input type="checkbox"/>	<input type="checkbox"/>	
Visual checks						
Leaks	Annually	Annually	Every six months	<input type="checkbox"/>	<input type="checkbox"/>	
Bolt connections	Annually	Annually	Every six months	<input type="checkbox"/>	<input type="checkbox"/>	
Terminal box cover	Annually	Annually	Every six months	<input type="checkbox"/>	<input type="checkbox"/>	
Cable connections tight	Annually	Annually	Every six months	<input type="checkbox"/>	<input type="checkbox"/>	
External damage	Annually	Annually	Every six months	<input type="checkbox"/>	<input type="checkbox"/>	
Functional inspection						
Motor functions, running noises		Annually	Annually	<input type="checkbox"/>	<input type="checkbox"/>	
Max. lifting path		Annually	Annually	<input type="checkbox"/>	<input type="checkbox"/>	
Terminal box and cable infeed leak tightness		Annually	Annually	<input type="checkbox"/>	<input type="checkbox"/>	
Position indicator, signals, adjustment		Annually	Annually	<input type="checkbox"/>	<input type="checkbox"/>	
Extended test						
Actuating force measurement			Every 2-3 years	<input type="checkbox"/>	<input type="checkbox"/>	
Reset force measurement			Every 2-3 years	<input type="checkbox"/>	<input type="checkbox"/>	
Power consumption measurement			Every 2-3 years	<input type="checkbox"/>	<input type="checkbox"/>	
Insulation resistance measurement			Every 2-3 years	<input type="checkbox"/>	<input type="checkbox"/>	
Coil resistance measurement			Every 2-3 years	<input type="checkbox"/>	<input type="checkbox"/>	

Test object	Test interval according to classification		Test performed	Test passed	Evaluation / measured values
Proof of insulation reliability in accordance with DIN 57530 part 1 / VDE 0530 section 17.1		Every 2-3 years	<input type="checkbox"/>	<input type="checkbox"/>	
Maintenance Replacing all wear parts (bearings, seals, operating fluids, etc.)		Recommendation: Every 5 years or after 5 million switching cycles			

Summary	Complete test passed	Repair required	Next test
	<input type="checkbox"/>	<input type="checkbox"/>	

Confirmation				
The test was performed in accordance with the manufacturer's maintenance manual.				
	Location/date	Company	Tester	Signature

9.2.1 Classification

Table 25. Classification

Classification	Low requirements	Standard	Higher requirements
By safety profile	Applications in functions and areas with low safety requirements	Applications in functions and areas with normal safety requirements	Applications in functions and areas with very high safety requirements
Or by operating profile	Mainly at a standstill, operation irregular and seldom	Operated in average value ranges of the permissible operating data according to type plate	Operated in limit value ranges of the permissible operating data according to type plate
Test run	Every six months		
Visual checks	Annually	Annually	Every six months
Functional inspection		Annually	Annually
Extended test			Every 2-3 years
Maintenance		Recommendation: 5 years or after 5 million switching cycles	

10 Disassembly

The following safety regulations must be adhered to before beginning any work on ELDRO® thrusters:

- Ensure that the industrial system is shut down.
- De-energise the system.
- Safeguard the system to prevent it being switched on again.
- Test to ensure a de-energised state.
- Cover or isolate adjacent live parts.



WARNING

Opening the ELDRO® thrusters

Risk of injury due to tensioned c springs.

- Only service partners authorised by the manufacturer are permitted to dismantle the ELDRO® thrusters outside the manufacturer's factory.



CAUTION

Switch-off due to any c springs, brake springs, brake weights that may be installed or due to other external influences

Risk of crushing due to the lifting rod.

- Before removing the ELDRO® thrusters, the downstream drive must be secured, as the lifting rod retracts automatically.

10.1 Disconnecting the electrical connections

DANGER

Live components

Fatal electric shock or serious burns.

- Work on live components may only be performed by electricians.
- First disconnect the electrical power supply.
- The earthing conductor must be disconnected after all other cables.



Observe the allocations in the terminal diagram (⇒Assembly chapter, Electrical connection section).

- First disconnect the electrical power supply.
- Disconnect the earthing conductor after all other cables.

10.2 Removal

CAUTION

Switch-off due to any c springs, brake springs, brake weights that may be installed or due to other external influences

Risk of crushing due to the lifting rod.

- Before removing the ELDRO® thrusters, the downstream drive must be secured, as the lifting rod retracts automatically.

CAUTION

The ELDRO® thrusters weigh between 10 and 70 kg

Risk of injury when lifting the load manually.

- Use suitable lifting equipment (e.g. crane).
- Never remain below suspended loads.
- Use a transport aid (e.g. lifting carriage) with sufficient load bearing capacity.

INFORMATION

Suitable measures must be taken to prevent the ELDRO® thrusters falling before removing them. The ELDRO® thrusters weigh between 10 and 70 kg.

INFORMATION

The lifting rod must not be damaged or contaminated (e.g. by paint as a result of painting the entire system). A failure to observe this will destroy the lifting rod.

Process

1. Secure the ELDRO® thrusters to prevent them falling.
2. Pull the bolt out of the lifting rod.
3. Attach the lifting gear to the ELDRO® thruster.
4. Remove the bolt from the foot hole.
5. Use the lifting gear to remove the ELDRO® thruster.

11 Disposal

11.1 Disposal consideration



WARNING

Opening the ELDRO® thrusters

Risk of injury due to tensioned c springs.

- Only service partners authorised by the manufacturer are permitted to dismantle the ELDRO® thrusters outside the manufacturer's factory.

The manufacturer can dispose of ELDRO® thrusters for a charge in accordance with the applicable terms and conditions after they have been dismantled properly.

When disposing of the ELDRO® thrusters and their process media, observe the following points:

- Observe national regulations on site.
- Observe company-specific requirements.
- Dispose of the operating fluid (oil filling), the plastic parts and the metal parts separately.
- Used process media must be disposed of in accordance with the respective valid safety data sheets.



In the event that disposal is necessary, it is advisable to entrust authorised disposal companies with the disposal to ensure that the legal regulations applicable at the place of operation regarding collection, reuse or disposal as well as record keeping are complied with.

12 Lists

12.1 Index of figures

Figure 1.	Type designation and type key	18
Figure 2.	Type plate	19
Figure 3.	Type ED120 / ED220	26
Figure 4.	Type ED300 / ED500	27
Figure 5.	Type ED500 / ED800 / ED1250	28
Figure 6.	Type ED500 / ED800	29
Figure 7.	Type ED1250 – ED3500	30
Figure 8.	Type ED1250 – ED3500	31
Figure 9.	ELDRO® thruster ED120 / ED220 layout	35
Figure 10.	ELDRO® thruster ED300 / ED500 layout	36
Figure 11.	ELDRO® thruster ED500 / ED1250 layout	37
Figure 12.	Rotatable thruster base	38
Figure 13.	Cable gland	39
Figure 14.	Heating rod	41
Figure 15.	Attachment point	44
Figure 16.	Permissible installation positions	48
Figure 17.	6-pin terminal diagram	51
Figure 18.	9-pin terminal diagram with heating	52
Figure 19.	9-pin terminal diagram without heating	53
Figure 20.	Temperature measurement points	57
Figure 21.	Adjustment screws H and S	58
Figure 22.	Lifting/lowering valve adjustment parts	59
Figure 23.	Rotating the thruster base	60
Figure 24.	Operating fluid fill height	70
Figure 25.	Topping up the operating fluid	71

12.2 Index of tables

Table 1.	Format conventions	8
Table 2.	Terms and abbreviations	10
Table 3.	Responsible staff	15
Table 4.	ED120 / ED220 key data	20
Table 5.	ED300 key data	21
Table 6.	ED500 key data	21
Table 7.	ED800 key data	22
Table 8.	ED1250 key data	22
Table 9.	ED1500 key data	23
Table 10.	ED1850 / ED2000 key data	23
Table 11.	ED2500 key data	24
Table 12.	ED3000 key data	25
Table 13.	ED3500 key data	25
Table 14.	ED120 / ED220 dimensions	26
Table 15.	ED300 / ED500 dimensions	27
Table 16.	Dimensions ED500 / ED800 / ED1250 - Short lifting thrusters	28
Table 17.	Dimensions ED500 / ED800 - Long lifting thrusters	29

Table 18.	Dimensions ED1250 – ED3500 – Short lifting thrusters	30
Table 19.	Dimensions ED1250 – ED3500 – Long lifting thrusters	31
Table 20.	Operating behaviour depending on the ambient temperature	32
Table 21.	Faults and troubleshooting.....	64
Table 22.	Fill quantities for operating fluid	68
Table 23.	ELDRO® thruster type / Distance value H	70
Table 24.	Maintenance log for ELDROclassic® lifting thrusters	72
Table 25.	Classification	73
Table 26.	Further applicable documents.....	80

